

WATER QUALITY TRADING PLAN

June 6, 2022



City of Shullsburg
Wastewater Treatment Facility
WPDES Permit No. WI-0028321-08-1
780 West Water Street
Shullsburg, Wisconsin 53586

Prepared by:

Delta 3 Engineering, Inc.

875 S Chestnut St. | Platteville, WI 53818

Phone: (608) 348-5355

mail@delta3eng.biz

www.delta3eng.biz



Project Number: D21-007

TABLE OF CONTENTS

I.	Executive Summary.....	1
II.	Background.....	2
III.	Location and Description of Credit Generation Sites.....	4
IV.	Methods for Nonpoint Source Load Reduction.....	6
V.	Trade Timeline.....	9
VI.	Inspection and Reporting.....	10
VII.	Certification.....	12

Attachments

- 1) Notice of Intent to Conduct Water Quality Trading
- 2) Water Quality Trading Checklist
- 3) Location & Topography Map
- 4) Sanitary Sewer Map
- 5) Wastewater Treatment Facility Flow Schematic
- 6) HUC-12 Watershed Map
- 7) Wetland Map
- 8) Soils Map and Testing Data
- 9) Current State of Eroding Streambanks Documentation
- 10) NRCS Streambank Erosion Estimator Report
- 11) Operation and Maintenance (O&M) Plan
- 12) WQT Plans and Specifications

I. Executive Summary -

This Water Quality Trading Plan summarizes the City of Shullsburg’s (City) plan to utilize Water Quality Trading (WQT) for compliance with the final total phosphorus limit as provided in the Wisconsin Pollutant Discharge Elimination System (WPDES) Permit #WI 0028321-08-1. The Wastewater Treatment Facility (WWTF) treated 0.1812 MGD in 2020 and 0.1650 MGD in 2021. The WWTF had an average effluent Total Phosphorus (TP) concentration of 0.07 mg/L in 2021. The WWTF plans to continue chemical Phosphorus treatment and offset 107 lbs. of TP with WQT Credits in order to help consistently meet the final annual six-month average limit of 0.075 mg/L and a monthly average limit of 0.22 mg/L.

NRCS Streambank Erosion modeling methods were used to calculate the total phosphorus credits that would be generated based on the installation of best management practices (BMPs). These credits will be used in order to reduce the amount of chemical the WWTF uses to treat wastewater for Total Phosphorus.

As demonstrated in modeling results from Table 1.1, the WWTF has the ability to register approximately 107 credits. The WWTF intends to monitor TP credit usage and intends to perform construction of additional BMPs as needed for future effluent TP to comply with WPDES Permits Limits. A new Water Quality Trading Plan will be submitted at that time for new BMP practices and credit production.

Table 1.1 – Modeling Results

Reach	Lateral Recession Rate (ft/yr.)	Current Phosphorus Loading (lbs./yr.)	Proposed Phosphorus Loading (lbs./yr.)	Proposed Phosphorus Reductions (lbs./yr.)	Trade Ratio	Proposed Phosphorus Credits
1 (Right)	0.35	116	0	116	3:1	39
2 (Right)	0.20	130	0	130	3:1	43
3 (Right)	0.45	75	0	75	3:1	25
Total						107

NOTE:

Trade Ratio = (Delivery + Downstream + Equivalency + Uncertainty – Habitat Adjustment):1

Delivery = 0 (Trading within same HUC-12 Watershed)

Downstream = 0 (All trades are upstream of Outfall 001)

Equivalency = 0 (Not necessary of Total Phosphorus)

Uncertainty: *Streambank Stabilization without Habitat Restoration* = 3

II. Background -

The purpose of this Water Quality Trading Plan (Plan) is to describe the City's use of Water Quality Trading to offset effluent phosphorus and allow the WWTF to reduce the amount of chemical used in order to comply with the total phosphorus limits as provided in the City's WPDES Permit #WI-0028321-08-1. Along with the Water Quality Trading Plan, the Notice of Intent to Conduct Water Quality Trading is provided in Attachment #1, dated June 6, 2022, while the Water Quality Trading Checklist Form 3400-208 is provided in Attachment #2.

The City of Shullsburg (City) is located along State Trunk Highway '11' in the southern portion of Lafayette County in Southwest Wisconsin. The City owns and operates a Wastewater Treatment Facility (WWTF) which serves a population of approximately 1,226 residents.

The City is comprised primarily of commercial and residential development. The City is situated between along the Shullsburg Branch. The City has many rolling hills with the grade typically sloping between 5% and 15%. Elevations in the area range from approximately 905'± at the WWTF to 1,058'± at the Water Tower, which is located at the south end of the City. The topography of the area is shown in Attachment #3.

The existing sanitary sewer collection consists of approximately 231 sanitary manholes; eight (8) sanitary sewer cleanouts/lampholes; 44,160 feet of eight-inch (8") sanitary sewer; 2,880 feet of 10" sanitary sewer; and 3,680 feet of 12" sanitary sewer. One (1) lift station is utilized throughout the system along with approximately 1,140 feet of four-inch (4") sanitary force main to assist with the delivery of wastewater to the WWTF. Please refer to Attachment #4 – Sanitary Sewer Map for location of sanitary sewer collection system components.

The City of Shullsburg owns and operates a WWTF that utilizes a standard activated sludge treatment system. Wastewater enters the WWTF by first passing through the headworks, which consists of a vertical screen and a bypass bar screen. Wastewater then proceeds to the primary clarifier, rotating biological contactors, and aeration tanks. Activated sludge is settled out in the final clarifier and chemical is added prior to the clarifier for Total Phosphorus treatment. Activated sludge is either returned to the head of the process for further treatment or wasted to aerobic digestors and stored prior to land application on DNR approved sites. The current WWTF treats 0.1650 MGD on an annual average with a design flow of 0.2885 MGD. Please see Attachment #5 for the WWTF flow schematic. The City of Shullsburg's WWTF has two (2) receiving water and effluent discharge locations: the Shullsburg Branch (001) and Tributary of Shullsburg Branch (Outfall 002) (Galena River Watershed, GP01 – Grant-Platte River Basin).

The monthly average influent and effluent flows and loadings at the WWTF for 2020/2021 are provided in Table 2.1 and Table 2.2.

Table 2.1 – 2020 Monthly Averages

Month	Flow	BOD ₅		Suspended Solids		Total Phosphorus		Total Phosphorus
	(MGD)	(mg/L)		(mg/L)		(mg/L)		(lbs./day)
	Effluent	Influent	Effluent	Influent	Effluent	Influent	Effluent	Effluent
Jan. ('20)	0.1811	207	6	263	7	-	0.07	0.1
Feb. ('20)	0.1840	161	5	559	8	-	0.08	0.12
Mar. ('20)	0.2019	230	5	367	8	-	0.09	0.15
Apr. ('20)	0.1723	294	6	415	9	-	0.18	0.26
May ('20)	0.1581	265	5	386	14	-	0.07	0.09
June ('20)	0.1671	209	11	299	17	-	0.11	0.15
July ('20)	0.2069	175	11	274	11	-	0.06	0.10
Aug. ('20)	0.1744	255	6	380	5	-	0.11	0.16
Sept. ('20)	0.1760	214	2	425	5	-	0.05	0.07
Oct. ('20)	0.1775	336	2	777	4	-	0.04	0.06
Nov. ('20)	0.1833	350	2	1280	4	-	0.04	0.06
Dec. ('20)	0.1912	242	2	283	6	-	0.06	0.10
Annual Average =	0.1812	245	5	476	8	-	0.08	0.12

Table 2.2 – 2021 Monthly Averages

	Flow	BOD ₅		Suspended Solids		Total Phosphorus		Total Phosphorus
	(MGD)	(mg/L)		(mg/L)		(mg/L)		(lbs./day)
	Effluent	Influent	Effluent	Influent	Effluent	Influent	Effluent	Effluent
Jan. ('21)	0.1781	374	2	913	6	-	0.06	0.09
Feb. ('21)	0.1802	348	2	503	6	-	0.08	0.12
Mar. ('21)	0.1644	286	2	243	9	-	0.08	0.11
Apr. ('21)	0.1617	252	2	211	7	-	0.08	0.11
May ('21)	0.1515	281	3	466	4	-	0.06	0.08
June ('21)	0.1556	272	5	430	4	-	0.06	0.08
July ('21)	0.1526	309	2	474	3	-	0.04	0.05
Aug. ('21)	0.1524	255	5	378	5	-	0.07	0.09
Sept. ('21)	0.1535	150	4	231	5	-	0.05	0.06
Oct. ('21)	0.1672	239	3	204	4	-	0.04	0.06
Nov. ('21)	0.1816	198	3	251	4	-	0.21	0.32
Dec. ('21)	0.1809	220	3	261	5	-	0.06	0.09
Annual Average =	0.1650	265	3	380	5	-	0.07	0.10

To reduce effluent TP, the City has made efforts to optimize TP reduction at the WWTF. The City also enforces industrial discharge permits with White Hill Cheese and the Shullsburg

Creamery. Currently, the City has been able to maintain an average Total Phosphorus effluent of 0.07 mg/L which is well within the WPDES limit of 0.22 mg/L. However, the WWTF has had difficulties consistently meeting the six-month average limit of 0.075 mg/L. Additionally, the City wishes to reduce the amount of chemical used for Total Phosphorus treatment.

Additionally, the City has investigated watershed compliance alternatives such as Water Quality Trading (WQT) and Adaptive Management (AM). According to the Surface Water Integrated Monitoring System database, as stated in the City's Water Quality Based Effluent Limit (WQBEL), the Shullsburg Branch is considered to be impaired water due to TP. As stated in the WQBEL, a background TP concentration of 0.116 mg/L is assumed for the Shullsburg Branch based on a weighted average from 18 monitoring stations in the surrounding HUC 8 Watershed. The weighted average was almost double the applicable Water Quality Standard (WQS) of 0.075 mg/L. Following discussion with the County and initial investigation, the City elected to move forward with WQT. Utilizing the results from PRESTO, the watershed of the WWTF has a nonpoint source ratio of 17:83 at the point of discharge and is considered to be nonpoint-source dominated. Therefore, the City intends to perform WQT projects upstream of the outfall but within the City's Hydrological Unit Code – 12 (HUC-12) watershed #070600050303 as provided in Attachment #6.

For the proposed Water Quality Trading Plan, it was determined that the City would be able to generate 107 credits per year. WQT credits were calculated using the NRCS Streambank Erosion modeling methods.

III. Location and Description of Credit Generation Sites –

The City discharges to the Shullsburg Branch (Outfall 001) and Tributary of Shullsburg Branch (Outfall 002). Both receiving waters are part of the Galena River Watershed, GP01 – Grant-Platte River Basin. As mentioned previously, the City intends to perform WQT projects within the Village's HUC-12 #070600050303. The City plans to perform streambank stabilization which will utilize grading and/or riprap to prevent the erosion of sediment from the streambanks. Projects will occur on private property. Streambank stabilization will not only prevent sediment from entering the stream, but will also prevent phosphorus, nitrogen, and other pollutants from discharging to the Shullsburg Branch. See Figure 3.1 for additional project location information.



Figure 3.1 – Project location in relation to Outfall 001 and Outfall 002

IV. Methods for Nonpoint Source Load Reduction –

The City would like to acquire 107 WQT trading credits for a safety factor in the event that effluent credits are lost or the WWTF discharges additional mass of TP. The Plan identifies trading practices that will reduce TP runoff by more than 322 lbs. and will utilize a 3:1 trade ratio for upstream trades. The WQT practices identified for this Water Quality Trading Plan has the ability to generate approximately 107 TP credits/year indefinitely as long as trading practices are maintained.

A. Methods Used to Generate Load Reductions

For streambank stabilization, the City has the ability to generate TP load reductions through streambank grading and/or riprapping of approximately 1,740 lineal feet of streambank.

Streambank Stabilization will be performed as per NR 328 *Shore Erosion Control Structures in Navigable Waterways* and NRCS 580 *Streambank and Shoreline Protection*. Streambank shaping and/or riprapping will eliminate the discharge of sediment to the stream. The streambank stabilization project will occur within HUC-12 #070600050303 in order to generate TP credits. Standard Plans and Specifications for the Project Site will be provided by a Professional Engineer. The City will also acquire all required permits and authorizations for the Projects.

To register credits, the City has entered into trade agreements with Property Owners pursuant to *s. 283.84(1)(b), Wis. Stats.*

B. History of Project Site

The Project Site is planned within the Galena River Watershed along the Shullsburg Branch. No mapped wetlands will be impacted by the WQT Project as indicated in Attachment #7 – Wetland Map.

The project location is planned on private property along Shullsburg Branch. Adjacent land use consists of agriculture cropland, manicured lawn, and a campground. The vegetative cover is primarily grass and brush.

The streambanks have experienced significant erosion as the Shullsburg Branch has been cleared for agricultural use. The banks are bare with slumps, rills and sever vegetative overhang throughout. Severe erosion indicators such as undercuts, slumps, tree roots, and fallen trees are readily visible throughout the site. The erosion indicators demonstrate the lateral recession rate is Severe (0.3-0.5 ft/yr) based on the NRCS Recession Rate Table.

C. Model Used to Derive Load Reductions

NRCS Streambank Erosion modeling methods were used to calculate the total phosphorus credits that would be generated based on the installation of BMPs. These credits will be used to demonstrate compliance with the final total phosphorus limit as proposed in the WPDES Permit. Modeling results are provided in Table 4.2. If the Plan or model inputs change during construction, the City will submit to the DNR the revised models and calculations to more accurately reflect and number of credits generated.

Table 4.2 – Modeling Results

Reach	Lateral Recession Rate (ft/yr.)	Current Phosphorus Loading (lbs./yr.)	Proposed Phosphorus Loading (lbs./yr.)	Proposed Phosphorus Reductions (lbs./yr.)	Trade Ratio	Proposed Phosphorus Credits
1 (Right)	0.35	116	0	116	3:1	39
2 (Right)	0.20	130	0	130	3:1	43
3 (Right)	0.45	75	0	75	3:1	25
Total						Total

NOTE:

Trade Ratio = (Delivery + Downstream + Equivalency + Uncertainty – Habitat Adjustment):1

Delivery = 0 (Trading within same HUC-12 Watershed)

Downstream = 0 (All trades are upstream of Outfall 001)

Equivalency = 0 (Not necessary of Total Phosphorus)

Uncertainty: *Streambank Stabilization without Habitat Restoration* = 3

Soil testing has been completed to determine TP concentrations within the soil. Soil sampling was performed approximately every 100 - 150 feet and included the use of a soil sampler which pulled ¾” cores at 8” depth. Approximately six (6) cores were taken at each sampling location to provide a representative sample. Soils maps and soil testing data is provided in Attachment #8. An onsite evaluation has been conducted to estimate stream bank recession rate. The data, narrative, and photos documenting the current state of eroding stream banks are provided in Attachment #9.

With the collected data, the NRCS Streambank Erosion Estimator was used to calculate TP loss from each reach of the eroding streambank. The modeling data for the NRCS Streambank Erosion Estimator is available in Attachment #10. The streambank grading and/or riprap design will eliminate streambank recession thus eliminating TP inputs within the Project areas.

Shullsburg Branch has experienced agricultural development within the watershed and has issues caused by sedimentation which was included in Wisconsin DNR evaluation for *Platte River Region*. Streambank improvements will reduce sediment which is the primary cause for habitat degradation in the Shullsburg Branch.

D. Operation and Maintenance

An Operation and Maintenance (O&M) Plan is provided in Attachment #11. The O&M plan describes how the Stream Stabilization Practices will be operated and maintained. The O&M Plan also addresses response procedures for Practice Registration, Noncompliance Notification, and Notification of Trade Agreement Termination.

As previously mentioned, the City is planning to perform streambank stabilization by implementing BMPs along the Shullsburg Branch streambanks. The stabilization practices will be installed and maintained per the Plans and Specifications as provided in Attachment #12. BMPs are to follow NR 328 Shore Erosion Control Structures in Navigable Waterways and NRCS 580 Streambank and Shoreline Protection. Restoration landscaping and seeding will be installed following construction and will be closely monitored for a minimum of two (2) growing seasons to ensure the new seeding grows and erosion is not prevalent. Weeds and invasive vegetation growth will be addressed if present.

The BMPs will be inspected annually by a licensed Professional Engineer to ensure that the BMPs are functioning as intended in order to meet the requirements of this WQT Plan.

V. Trade Timeline –

Schedule for Installation of the above mentioned trading practices for Total Phosphorus Credit Generation for TP compliance is provided in Table 5.1 below.

Table 5.1 – Trade Timeline

Item	Completion Timeline
Site Investigation	Summer 2021
Conceptual Design	Spring 2022
Final Design	Summer 2022
Construction Permits	Summer 2022
DNR Review of Final Design	Summer 2022
Construction of BMPs	Fall 2022
Phosphorus Credit Registration	Winter 2022
Use of Phosphorus Credits (Ongoing for Permit Compliance)	January 1, 2023

Credits will be used by the City beginning January 1, 2023. Credits will continue as long as the trading practices are maintained as outlined in this WQT Plan.

VI. Inspection Reporting –

A. Tracking Procedures

The City will track credits used monthly. The City will report credit usage to the DNR on a monthly basis in the Discharge Monitoring Reports (DMRs). The annual report will summarize the 12 months of credit usage and credit generation. The City will report to DNR any concern that they have that may result in a need to modify the trade agreement and/or this trade plan. For example, a need to generate additional credits based on discharge.

B. Inspection

Inspection of the BMPs shall occur during construction phase to ensure they are installed per the design and meet all applicable codes and permits. Once completed, inspections of the established BMPs shall occur each month at a minimum or following heavy rain events. A licensed professional engineer will perform an annual certification to ensure the practice is performing as designed and the City remains in compliance.

The inspection reports will include:

- i. Name and contact information of the inspector
- ii. Inspection Date
- iii. Relevant standards set forth in the Design Plan or Operation and Maintenance Plan
- iv. Issues identified
- v. When and how any issues identified were addressed
- vi. When and how any issues identified will be addressed in the future

Inspection reports generated during each routine or after rain event inspection will be included with the Annual Water Quality Trading Report submitted by the City to DNR. Annual inspections by a professional engineer will typically occur in April or May. This time of year is ideal for evaluating the condition of BMPs as it follows the freeze/thaw which poses the greatest potential for changes to the BMPs. Minimal vegetation cover will allow for adequate visual inspection.

C. Management Practice Registration Form

The City will file a completed registration form 3400-207 for Water Quality Trading Management Practice Registration separately from this Plan.

D. Annual Water Quality Trading Report Submittal

The following shall be submitted to the DNR by January 31 of each year:

- i. The number of pollutant reduction credits (lbs./month) used each month of the previous year to demonstrate compliance;
- ii. A summary of the annual inspection of the practice that generated any of the pollutant reduction credits used during the previous year, this inspection shall be completed by a licensed Professional Engineer;
- iii. All monthly inspection reports;

- iv. Identification of noncompliance or failure to implement any terms or conditions of this permit with respect to water quality trading that have not been reported in discharge monitoring reports;
- v. A list of all noncompliance and the correction measures and timing to address the issues throughout the year; and
- vi. An updated WQT plan if management practices have or will change.

E. Monthly Certification of Management Practices

Each month, the City will certify that the BMPs are maintained and operating in a manner consistent with this Water Quality Trading Plan or provide a statement noting noncompliance with this Plan. The monthly Discharge Monitoring Report (DMR) will include the following statement as a certification of compliance when the Credit Generating Practice is operating in a manner consistent with the Plan:

“I certify that to the best of my knowledge that the management practices identified in the approved water quality trading plan as the source of phosphorus credits is installed, established and properly maintained.”

F. Notification of Failure to Generate Credits

The City will notify DNR by telephone call to DNR’s regional wastewater compliance engineer within 24 hours or next business day of becoming aware that phosphorus credits used or intended for use by City are not being generated as outlined in this Water Quality Trading Plan.

The City will submit a written notification within five days after the City recognizes that the phosphorus credits are not being generated as outlined in the Trading Plan. DNR may waive the requirement for submittal for a written notice within five days and instruct the City to submit the written notice with the next regularly scheduled monitoring report required by City’s WPDES Permit.

The written notice will contain a description of how and why the TP credits are not being generated as outlined in the Water Quality Trading Plan, the steps taken or planned to prevent reoccurrence of the identified problems and the length of time anticipated it will take to address the issue.

The City will work to rectify the problem as laid out in the Operation and Maintenance Plans.

G. Conditions under which Management Practices May Be Inspected

Any DNR authorized officer, employee, or representative has the right to access and inspect the credit generating practice so long as the City’s trade agreement with the property owner(s) and this Water Quality Trading Plan remain in effect.

VII. Certification –

The undersigned hereby certifies that this Water Quality Trading Plan is accurate and correct to the best of his knowledge.

City of Shullsburg Wastewater Treatment Facility

By: 

Verne Jackson
Mayor
City of Shullsburg
190 N. Judgement Street
P.O. Box 580
Shullsburg, WI 53586
Telephone: (608) 965-4424
Email: mayor@cityofshullsburg.org

Attachment #1

Notice: Pursuant to s. 283.84, Wis. Stats., and ch. NR 217 Wis. Adm. Code, this form must be completed by any WPDES permittee that is using water quality trading as a method of complying with a permit limitation. Failure to complete this form would not result in penalties. Personal information collected will be used for administrative purposes and may be provided to requesters to the extent required by Wisconsin's Open Records Law (ss. 19.31 - 19.39, Wis. Stats.).

Applicant Information				
Permittee Name City of Shullsburg		Permit Number WI- 0028321-08-1	Facility Site Number	
Facility Address 780 West Water Street			City Shullsburg	State WI
			ZIP Code 53586	
Project Contact Name (if applicable) Jordan Fure (Delta 3 Eng.)	Address 875 South Chestnut Street	City Platteville	State WI	ZIP Code 53818
Project Name Proposed 2022 Streambank Improvements - Shullsburg Branch				
Receiving Water Name Shullsburg Branch	Parameter(s) being traded Total Phosphorus	HUC 12(s) 070600050303		

Is the permittee in a point or nonpoint source dominated watershed? Point source dominated
 (See PRESTO results - <http://dnr.wi.gov/topic/surfacewater/presto.html>) Nonpoint source dominated

Credit Generator Information	
Credit generator type (select all that apply):	<input type="checkbox"/> Permitted Discharge (non-MS4/CAFO) <input checked="" type="checkbox"/> Urban nonpoint source discharge <input type="checkbox"/> Permitted MS4 <input checked="" type="checkbox"/> Agricultural nonpoint source discharge <input type="checkbox"/> Permitted CAFO <input type="checkbox"/> Other - Specify: _____

Are any of the credit generators in a different HUC 12 than the applicant? Yes; HUC 12: _____
 No
 Unsure

Are any of the credit generators downstream of the applicant? Yes
 No
 Unsure

Will a broker/exchange be used to facilitate trade? Yes; Name: _____
 No
 Unsure

Point to Point Trades (Traditional Municipal / Industrial Discharge, MS4, CAFO)

Discharge Type	Permit Number	Name	Contact Address	Is the point source credit generator currently in compliance with their permit requirements?
<input type="radio"/> Traditional <input type="radio"/> MS4 <input type="radio"/> CAFO				<input type="radio"/> Yes <input type="radio"/> No <input type="radio"/> Unsure
<input type="radio"/> Traditional <input type="radio"/> MS4 <input type="radio"/> CAFO				<input type="radio"/> Yes <input type="radio"/> No <input type="radio"/> Unsure
<input type="radio"/> Traditional <input type="radio"/> MS4 <input type="radio"/> CAFO				<input type="radio"/> Yes <input type="radio"/> No <input type="radio"/> Unsure
<input type="radio"/> Traditional <input type="radio"/> MS4 <input type="radio"/> CAFO				<input type="radio"/> Yes <input type="radio"/> No <input type="radio"/> Unsure
<input type="radio"/> Traditional <input type="radio"/> MS4 <input type="radio"/> CAFO				<input type="radio"/> Yes <input type="radio"/> No <input type="radio"/> Unsure

Point to Nonpoint Trades (Non-permitted Agricultural, Non-Permitted Urban, etc.)

List the practices that will be used to generate credits:

The City intends to perform streambank stabilization. The construction will occur upstream of Outfall 001.

Method for quantifying credits generated: Monitoring
 Modeling, Names: NRCS Streambank Erosion Estimator
 Other: _____

Projected date credits will be available:

The preparer certifies all of the following:

- I am familiar with the specifications submitted for this application, and I believe all applicable items in this checklist have been addressed.
- I have completed this document to the best of my knowledge and have not excluded pertinent information.

Signature of Preparer 	Date Signed 6/6/2022
--	-------------------------

Authorized Representative Signature

I certify under penalty of law that this document and all attachments were prepared under my direction or supervision. Based on my inquiry of those persons directly responsible for gathering and entering the information, the information is, to the best of my knowledge and belief, accurate and complete. I am aware that there are significant penalties for submitting false information, including the possibility of fine and imprisonment for knowing violations.

Signature of Authorized Representative 	Date Signed 6-17-2022
---	--------------------------

Attachment #2

Notice: Pursuant to s. 283.84, Wis. Stats., this form must be completed by any WPDES permittee that intends to pursue pollutant trading as a method of complying with a permit limitation. Failure to complete this form would not result in penalties. Personal information collected will be used for administrative purposes and may be provided to requesters to the extent required by Wisconsin's Open Records Law (ss. 19.31 - 19.39, Wis. Stats.).

Applicant Information				
Permittee Name City of Shullsburg		Permit Number WI- 0028321-08-1		Facility Site Number
Facility Address 780 West Water Street			City Shullsburg	State WI
Project Contact Name (if applicable) Jordan Fure (Delta 3 Eng.)			Address 875 South Chestnut Street	City Platteville
			State WI	ZIP Code 53818
Project Name Proposed 2022 Streambank Improvements - Shullsburg Branch				
Receiving Water Name Shullsburg Branch		Parameter(s) being traded Total Phosphorus		HUC 12(s) 070600050303

Credit Generator Information	
Credit generator type (select all that apply):	<input type="checkbox"/> Permitted Discharge (non-MS4CAFO) <input type="checkbox"/> Urban nonpoint source discharge <input type="checkbox"/> Permitted MS4 <input checked="" type="checkbox"/> Agricultural nonpoint source discharge <input type="checkbox"/> Permitted CAFO <input type="checkbox"/> Other - Specify: _____
Are any of the credit generators in a different HUC 12 than the applicant?	<input type="radio"/> Yes; HUC 12: _____ <input checked="" type="radio"/> No
Are any of the credit generators downstream of the applicant?	<input type="radio"/> Yes <input checked="" type="radio"/> No
Will a broker/exchange be used to facilitate trade?	<input type="radio"/> Yes (include description and contact information in WQT plan) <input checked="" type="radio"/> No

Point to Point Trades (Traditional Municipal / Industrial, MS4, CAFO)
Are each of the point source credit generators identified in this section in compliance with their WPDES permit requirements? <input type="radio"/> Yes <input type="radio"/> No

Discharge Type	Permit Number	Name	Contact Information	Trade Agreement Number
<input type="radio"/> Traditional <input type="radio"/> MS4 <input type="radio"/> CAFO				
<input type="radio"/> Traditional <input type="radio"/> MS4 <input type="radio"/> CAFO				
<input type="radio"/> Traditional <input type="radio"/> MS4 <input type="radio"/> CAFO				
<input type="radio"/> Traditional <input type="radio"/> MS4 <input type="radio"/> CAFO				
<input type="radio"/> Traditional <input type="radio"/> MS4 <input type="radio"/> CAFO				

Water Quality Trading Checklist

Form 3400-208 (1/14)

Page 2 of 3

Point to Point Trades (Traditional Municipal / Industrial, MS4, CAFO) cont.

Does plan have a narrative that describes:		Plan Section
a. Summary of discharge and existing treatment including optimization	<input type="radio"/> Yes <input type="radio"/> No	
b. Amount of credit being generated	<input type="radio"/> Yes <input type="radio"/> No	
c. Timeline for credits and agreements	<input type="radio"/> Yes <input type="radio"/> No	
d. Method for quantifying credits	<input type="radio"/> Yes <input type="radio"/> No	
e. Tracking and verification procedures	<input type="radio"/> Yes <input type="radio"/> No	
f. Location of credit generator in proximity to receiving water and credit user	<input type="radio"/> Yes <input type="radio"/> No	
g. Other: _____	<input type="radio"/> Yes <input type="radio"/> No	

Point to Nonpoint Trades (Non-Permitted Urban, Agricultural, Other)

Discharge Type	Practices Used to Generate Credits	Method of Quantification	Trade Agreement Number	Have the practice(s) been formally registered?
<input type="radio"/> Urban NPS <input checked="" type="radio"/> Agricultural NPS <input type="radio"/> Other	Streambank Stabilization	NRCS Streambank Erosion Estimator		<input type="radio"/> Yes <input checked="" type="radio"/> No <input type="radio"/> Only in part
<input type="radio"/> Urban NPS <input type="radio"/> Agricultural NPS <input type="radio"/> Other				<input type="radio"/> Yes <input type="radio"/> No <input type="radio"/> Only in part
<input type="radio"/> Urban NPS <input type="radio"/> Agricultural NPS <input type="radio"/> Other				<input type="radio"/> Yes <input type="radio"/> No <input type="radio"/> Only in part
<input type="radio"/> Urban NPS <input type="radio"/> Agricultural NPS <input type="radio"/> Other				<input type="radio"/> Yes <input type="radio"/> No <input type="radio"/> Only in part
<input type="radio"/> Urban NPS <input type="radio"/> Agricultural NPS <input type="radio"/> Other				<input type="radio"/> Yes <input type="radio"/> No <input type="radio"/> Only in part
<input type="radio"/> Urban NPS <input type="radio"/> Agricultural NPS <input type="radio"/> Other				<input type="radio"/> Yes <input type="radio"/> No <input type="radio"/> Only in part
<input type="radio"/> Urban NPS <input type="radio"/> Agricultural NPS <input type="radio"/> Other				<input type="radio"/> Yes <input type="radio"/> No <input type="radio"/> Only in part
<input type="radio"/> Urban NPS <input type="radio"/> Agricultural NPS <input type="radio"/> Other				<input type="radio"/> Yes <input type="radio"/> No <input type="radio"/> Only in part

Does plan have a narrative that describes:		Plan Section
a. Description of existing land uses	<input checked="" type="radio"/> Yes <input type="radio"/> No	Section IV
b. Management practices used to generate credits	<input checked="" type="radio"/> Yes <input type="radio"/> No	Section IV
c. Amount of credit being generated	<input checked="" type="radio"/> Yes <input type="radio"/> No	Section IV
d. Description of applicable trade ratio per agreement/management practice	<input checked="" type="radio"/> Yes <input type="radio"/> No	Section IV
e. Location where credits will be generated	<input checked="" type="radio"/> Yes <input type="radio"/> No	Section III
f. Timeline for credits and agreements	<input checked="" type="radio"/> Yes <input type="radio"/> No	Section V
g. Method for quantifying credits	<input checked="" type="radio"/> Yes <input type="radio"/> No	Section IV

Water Quality Trading Checklist

Form 3400-208 (1/14)

Page 3 of 3

Does plan have a narrative that describes:		Plan Section
h. Tracking procedures	<input checked="" type="radio"/> Yes <input type="radio"/> No	Section IV
i. Conditions under which the management practices may be inspected	<input checked="" type="radio"/> Yes <input type="radio"/> No	Section VI
j. Reporting requirements should the management practice fail	<input checked="" type="radio"/> Yes <input type="radio"/> No	Section VI
k. Operation and maintenance plan for each management practice	<input checked="" type="radio"/> Yes <input type="radio"/> No	Section IV
l. Location of credit generator in proximity to receiving water and credit user	<input checked="" type="radio"/> Yes <input type="radio"/> No	Section III
m. Practice registration documents, if available	<input type="radio"/> Yes <input checked="" type="radio"/> No	
n. History of project site(s)	<input checked="" type="radio"/> Yes <input type="radio"/> No	Section IV
o. Other: _____	<input type="radio"/> Yes <input type="radio"/> No	

The preparer certifies all of the following:

- I am familiar with the specifications submitted for this application, and I believe all applicable items in this checklist have been addressed.
- I have completed this document to the best of my knowledge and have not excluded pertinent information.
- I certify that the information in this document is true to the best of my knowledge.

Signature of Preparer <i>John James</i>	Date Signed <i>6/6/2022</i>
--	--------------------------------

Authorized Representative Signature

I certify under penalty of law that this document and all attachments were prepared under my direction or supervision. Based on my inquiry of those persons directly responsible for gathering and entering the information, the information is, to the best of my knowledge and belief, accurate and complete. I am aware that there are significant penalties for submitting false information, including the possibility of fine and imprisonment for knowing violations.

Signature of Authorized Representative <i>Jan Braker</i>	Date Signed <i>6-17-2022</i>
---	---------------------------------

Attachment #3



City Location Map



- Legend**
- Municipality
 - State Boundaries
 - County Boundaries
 - Major Roads**
 - Interstate Highway
 - State Highway
 - US Highway
 - County and Local Roads**
 - County HWY
 - Local Road
 - Railroads
 - Tribal Lands
 - Rivers and Streams
 - Intermittent Streams
 - Lakes and Open water
 - Index to EN_Image_Basemap_Leaf_Off



NAD_1983_HARN_Wisconsin_TM

1: 15,840

DISCLAIMER: The information shown on these maps has been obtained from various sources, and are of varying age, reliability and resolution. These maps are not intended to be used for navigation, nor are these maps an authoritative source of information about legal land ownership or public access. No warranty, expressed or implied, is made regarding accuracy, applicability for a particular use, completeness, or legality of the information depicted on this map. For more information, see the DNR Legal Notices web page: <http://dnr.wi.gov/legal/>

Notes
Attachment #3

Attachment #4

Sanitary Sewer Map City of Shullsburg, WI

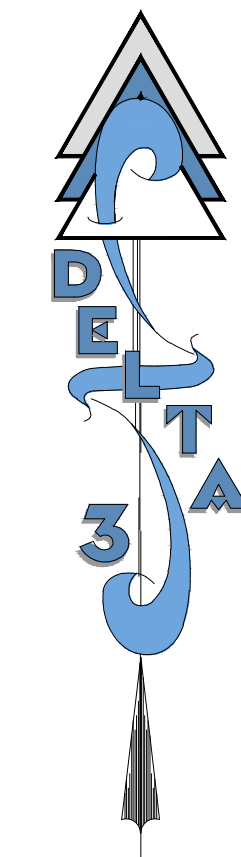
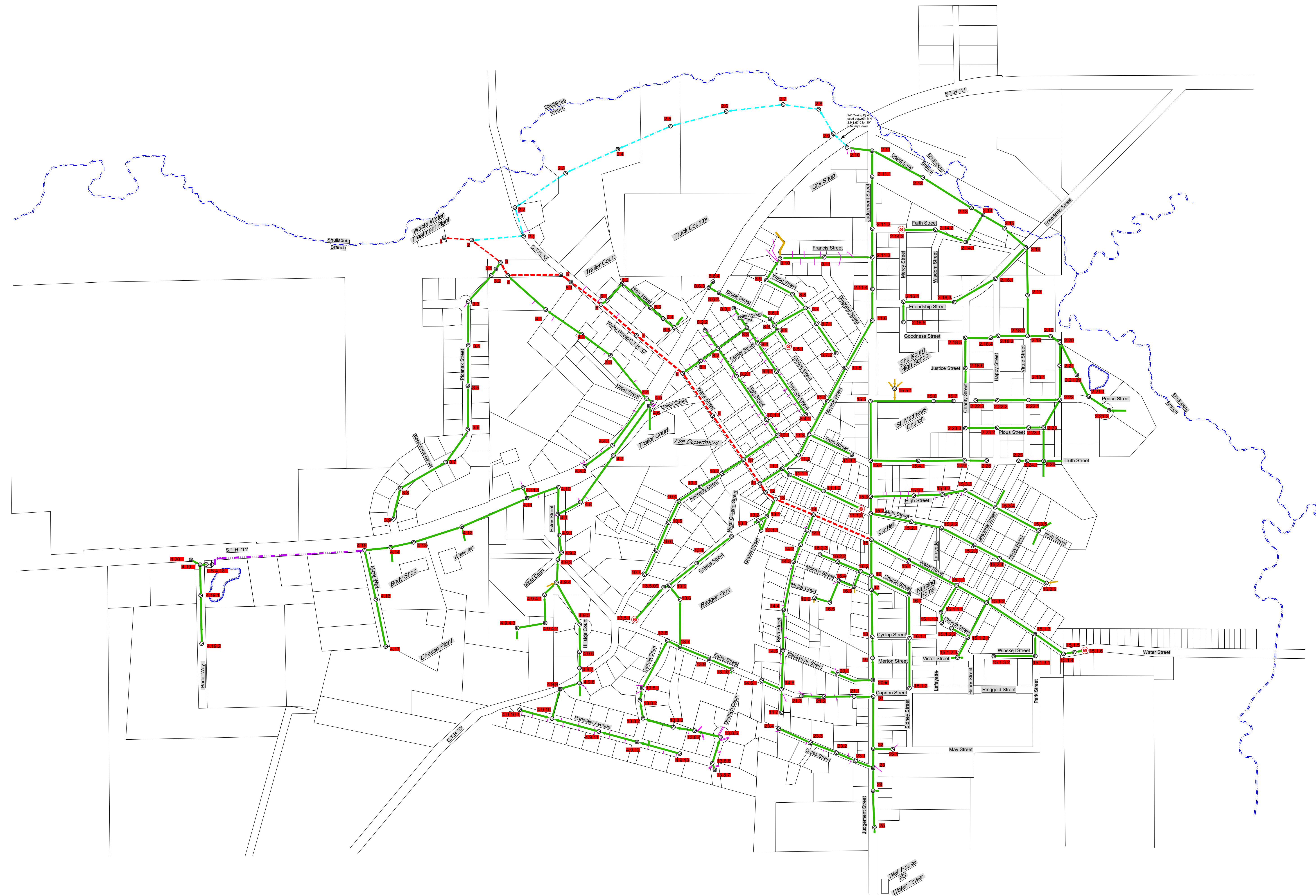

LEGEND

- Sanitary Manhole
- Sanitary Clean Out
- 6" Sanitary Sewer
- 8" Sanitary Sewer
- 10" Sanitary Sewer
- 12" Sanitary Sewer
- 24" Sanitary Sewer
- 4" Sanitary Forcemain
- Street Right-of-Way
- Lot Line
- Sanitary Service



Drawn by: C. Coyler
Date: February 3, 2012
Revised by: B. Piotrowski
Date: April, 2020



Attachment #5

Figure 3

CITY OF SHULLSBURG
Wastewater Treatment Plant Process Diagram

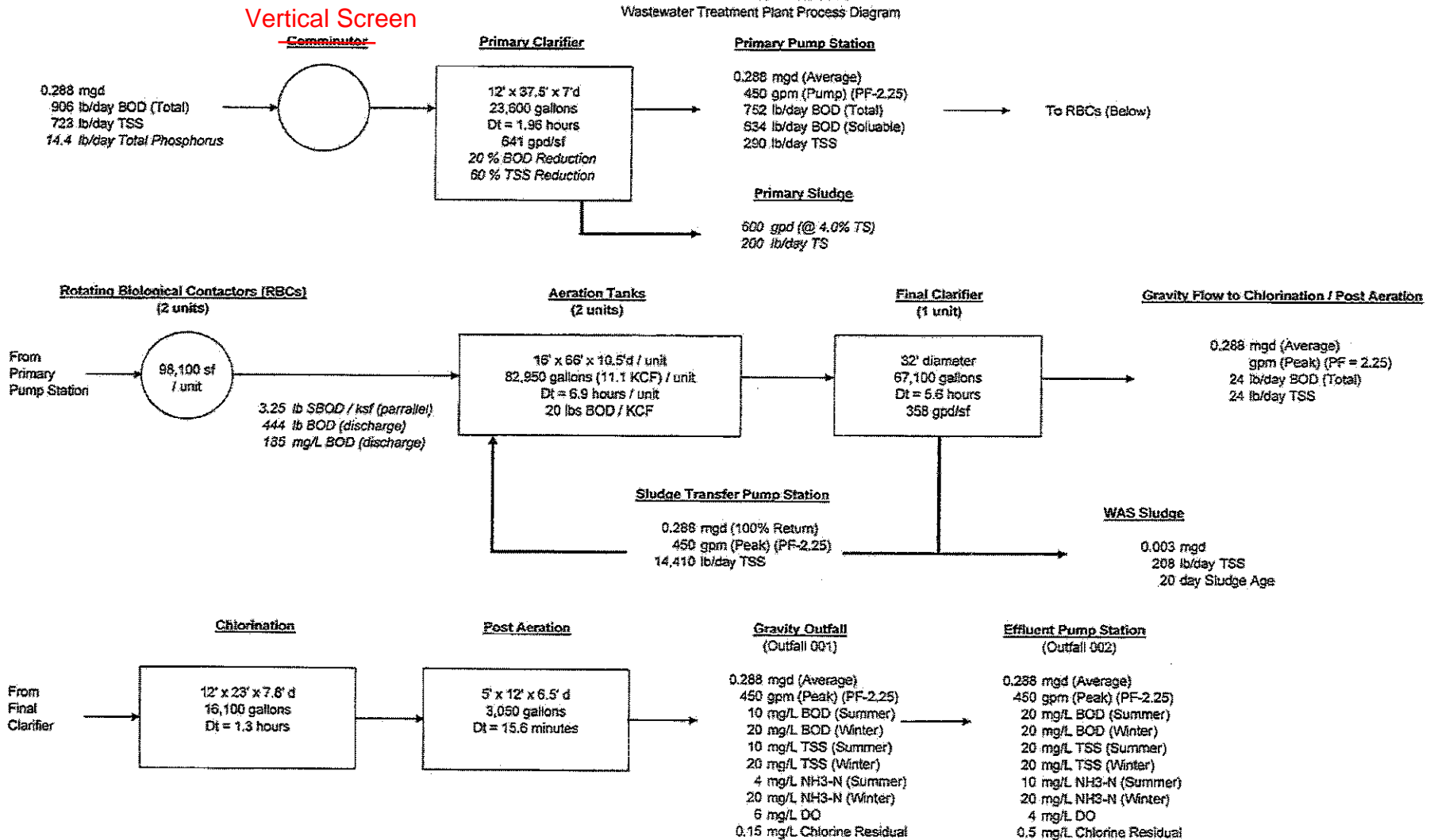

Attachment #6



HUC-12 Watershed Map

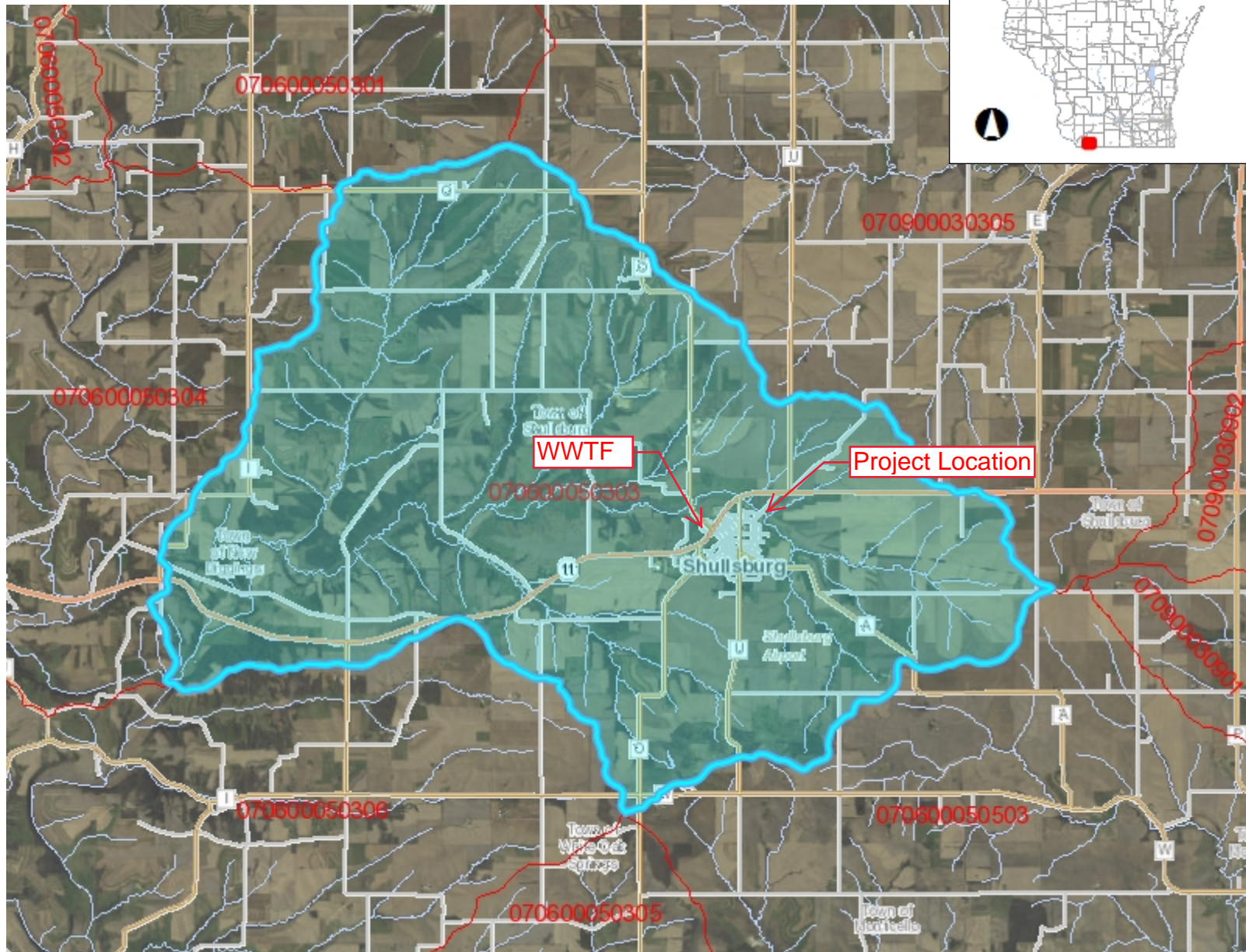

- Legend**
- 12-digit HUCs (Subwatersheds)
 - Municipality
 - State Boundaries
 - County Boundaries
 - Major Roads**
 - Interstate Highway
 - State Highway
 - US Highway
 - County and Local Roads**
 - County HWY
 - Local Road
 - + Railroads
 - Tribal Lands
 - Rivers and Streams
 - Intermittent Streams
 - Lakes and Open water
 - Index to EN_Image_Basemap_Leaf_Off

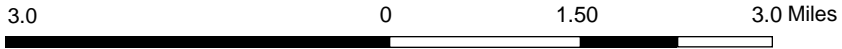

NAD_1983_HARN_Wisconsin_TM

1: 95,040

DISCLAIMER: The information shown on these maps has been obtained from various sources, and are of varying age, reliability and resolution. These maps are not intended to be used for navigation, nor are these maps an authoritative source of information about legal land ownership or public access. No warranty, expressed or implied, is made regarding accuracy, applicability for a particular use, completeness, or legality of the information depicted on this map. For more information, see the DNR Legal Notices web page: <http://dnr.wi.gov/legal/>

Notes

Attachment #7



Wetland Map



- Legend**
- Wetland Class Areas
 - Wetland Class Points
 - Dammed pond
 - Excavated pond
 - Filled/draind wetland
 - Wetland too small to delineate
 - Filled excavated pond
 - Filled Points
 - Wetland Class Areas
 - Filled Areas
 - Wetland Class Areas
 - Wetland Class Points
 - Dammed pond
 - Excavated pond
 - Filled/draind wetland
 - Wetland too small to delineate
 - Filled excavated pond
 - Filled Points
 - Wetland Class Areas
 - Filled Areas
 - Wetland Identifications and Confirmations
 - Municipality
 - State Boundaries
 - County Boundaries
 - Major Roads**
 - Interstate Highway
 - State Highway
 - US Highway
 - County and Local Roads**
 - County HWY
 - Local Road
 - Railroads
 - Tribal Lands
 - Railroads



NAD_1983_HARN_Wisconsin_TM

1: 3,960

DISCLAIMER: The information shown on these maps has been obtained from various sources, and are of varying age, reliability and resolution. These maps are not intended to be used for navigation, nor are these maps an authoritative source of information about legal land ownership or public access. No warranty, expressed or implied, is made regarding accuracy, applicability for a particular use, completeness, or legality of the information depicted on this map. For more information, see the DNR Legal Notices web page: <http://dnr.wi.gov/legal/>

Notes

Attachment #8

Soil Map—Lafayette County, Wisconsin



Soil Map may not be valid at this scale.

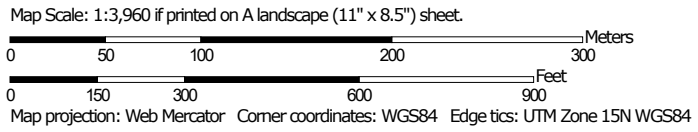

MAP LEGEND

Area of Interest (AOI)

 Area of Interest (AOI)

Soils

 Soil Map Unit Polygons

 Soil Map Unit Lines

 Soil Map Unit Points

Special Point Features



Blowout



Borrow Pit



Clay Spot



Closed Depression



Gravel Pit



Gravelly Spot



Landfill



Lava Flow



Marsh or swamp



Mine or Quarry



Miscellaneous Water



Perennial Water



Rock Outcrop



Saline Spot



Sandy Spot



Severely Eroded Spot



Sinkhole



Slide or Slip



Sodic Spot



Spoil Area



Stony Spot



Very Stony Spot



Wet Spot



Other



Special Line Features

Water Features



Streams and Canals

Transportation



Rails



Interstate Highways



US Routes



Major Roads



Local Roads

Background



Aerial Photography

MAP INFORMATION

The soil surveys that comprise your AOI were mapped at 1:15,800.

Warning: Soil Map may not be valid at this scale.

Enlargement of maps beyond the scale of mapping can cause misunderstanding of the detail of mapping and accuracy of soil line placement. The maps do not show the small areas of contrasting soils that could have been shown at a more detailed scale.

Please rely on the bar scale on each map sheet for map measurements.

Source of Map: Natural Resources Conservation Service

Web Soil Survey URL:

Coordinate System: Web Mercator (EPSG:3857)

Maps from the Web Soil Survey are based on the Web Mercator projection, which preserves direction and shape but distorts distance and area. A projection that preserves area, such as the Albers equal-area conic projection, should be used if more accurate calculations of distance or area are required.

This product is generated from the USDA-NRCS certified data as of the version date(s) listed below.

Soil Survey Area: Lafayette County, Wisconsin

Survey Area Data: Version 18, Sep 9, 2021

Soil map units are labeled (as space allows) for map scales 1:50,000 or larger.

Date(s) aerial images were photographed: Dec 31, 2009—May 5, 2016

The orthophoto or other base map on which the soil lines were compiled and digitized probably differs from the background imagery displayed on these maps. As a result, some minor shifting of map unit boundaries may be evident.

Map Unit Legend

Map Unit Symbol	Map Unit Name	Acres in AOI	Percent of AOI
An	Arenzville silt loam, 0 to 3 percent slopes, occasionally flooded	9.3	15.4%
AsC2	Ashdale silt loam, 6 to 12 percent slopes, moderately eroded	2.0	3.2%
EdD2	Edmund silt loam, 12 to 20 percent slopes, moderately eroded	0.9	1.4%
FeaB2	Festina silt loam, 1 to 6 percent slopes, moderately eroded	4.7	7.8%
HvA	Huntsville silt loam, 0 to 2 percent slopes	4.5	7.4%
HvB	Huntsville silt loam, 2 to 6 percent slopes	1.1	1.8%
On	Orion silt loam, 0 to 3 percent slopes, occasionally flooded	3.0	5.0%
Ow	Etrick silt loam, 0 to 2 percent slopes, frequently flooded	1.7	2.8%
Sb	Sable silt loam, benches	0.9	1.5%
TaB2	Tama silt loam, driftless, 2 to 6 percent slopes, moderately eroded	9.2	15.3%
TaC2	Tama silt loam, driftless, 6 to 12 percent slopes, moderately eroded	23.2	38.3%
Totals for Area of Interest		60.5	100.0%



710 Commerce Drive
PO Box 169
Watertown, WI 53094

920-261-0446 phone
920-261-1365 fax
www.rockriverlab.com

Total Phosphorus Analysis 06/04/2021

Field ID	Sample ID	Total P (ppm)
Shulls	1	1789
Shulls	2	1152
Shulls	3	328.1
Shulls	4	655.2
Shulls	5	1600
Shulls	6	890.1
Shulls	7	699.4
Shulls	8	834.3
Shulls	9	1041
Shulls	10	1085
Shulls	11	738.6
Shulls	12	1016
Shulls	13	923.3

Soil Total P

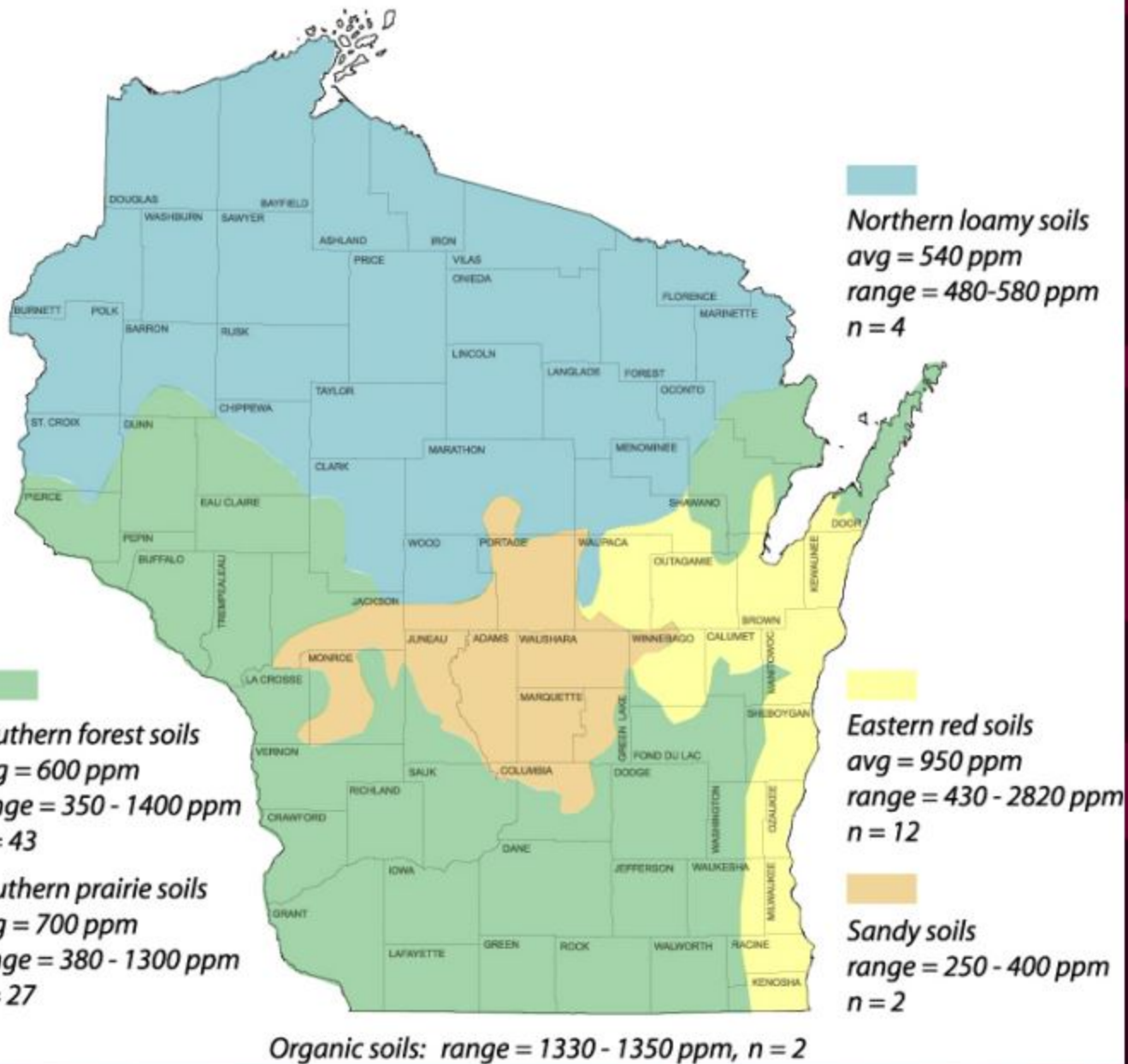

Attachment #9

ATTACHEMENT #9
TABLE OF CONTENTS

I. Introduction 1

II. Reach 1 1

III. Reach 2 2

III. Reach 3 3

I. Introduction

The lateral recession rate of the eroding bank is a critical component for the NRCS Streambank Erosion Estimator. The following documentation provides the justification for the lateral recession rates used in the NRCS Streambank Erosion Estimator. Lateral recession rate was estimated based on the photos provided, description, and on site evaluation. The following includes representative photos of the Project Extents to be stabilized through installation of Best Management Practices (BMPs).

II. Reach 1



Severe undercut with slump, vegetative overhang and exposed tree roots.



Moderate vegetative overhang and exposed tree roots.

III. Reach 2



Vegetative overhang and exposed tree roots. Old concrete curb and sidewalk had been placed at the stream corner in attempt to armor the channel. Water has scoured holes into the bank beneath the old concrete. The bank is planned for stabilization by grading to 6:1 slope and removal of the old concrete.



Vegetative overhang and exposed tree roots. Old concrete curb and sidewalk had been placed at the stream corner in attempt to armor the channel. Water has scoured holes into the bank beneath the old concrete. The bank is planned for stabilization by grading to 6:1 slope and removal of the old concrete.

IV. Reach 3



Severe undercut with slump, vegetative overhang, and exposed tree roots.



Severe undercut with slump, vegetative overhang, and exposed tree roots.



Severe undercut with slump, vegetative overhang, and exposed tree roots.



Severe undercut with vegetative overhang and exposed tree roots.



Severe undercut with vegetative overhang and exposed tree roots.



Severe undercut with vegetative overhang and exposed tree roots.

Attachment #10

NRCS Excel Workbook Estimating 'Other' Erosion Types June 2006

Annual soil loss predictions for conservation planning purposes are made with current soil loss prediction technology (RUSLE2). RUSLE2 estimates sheet, rill and interrill erosion. Erosion that is seasonal in nature and caused by concentrated flow, however, is not predicted by RUSLE2.

This workbook provides conservation planners with simple tools and processes to help estimate the amount of erosion occurring in ephemeral gullies, classic gullies and on streambank erosion sites.

Definitions:

Rill Erosion: consists of the removal of soil by concentrated water running through little streamlets, or headcuts. Detachment in a rill occurs if the sediment in the flow is below the amount the load can transport and if the flow exceeds the soil's resistance to detachment. As detachment continues or flow increases, rills will become wider and deeper. Rills may be of any size but are usually less than four inches deep. Rills are:

- <> generally parallel on the slope, but may converge,
- <> generally of uniform spacing and dimension,
- <> generally appear at different locations on the landscape from year to year,
- <> generally shorter than ephemeral cropland gullies,
- <> usually end at a concentrated flow channel, or an area where the slope flattens and deposition occurs,
- <> are on the same portion of the slope that is used to determine the length of slope (L) for RUSLE2,
- <> many small, but conspicuous channels running in the direction of slope gradient

Rill erosion is considered in the RUSLE2 calculations.

Ephemeral Gully Erosion: Small erosion channels formed on crop fields as a result of concentrated flow of runoff water. These channels are routinely eliminated by tillage of the field but return following subsequent runoff events. Ephemeral Gullies are small enough to be eliminated (temporarily) with the use of typical farm tillage equipment and they:

- <> recur in the same area of concentrated flow each time they form,
- <> frequently form in well-defined depressions in natural drainage ways,
- <> are generally wider, deeper, and longer than the rills in the field,

Ephemeral Gullies are not calculated by the RUSLE2 program.

Gully Erosion: Permanent gullies are formed when channel development has progressed to the point where the gully is too wide and too deep to be tilled across. These channels carry large amounts of water after rains and deposit eroded material at the foot of the gully. They disfigure landscape and make the land unfit for growing crops. Gullies:

- <> may grow or enlarge from year to year by head cutting and lateral enlarging,
- <> often occur in depressions or natural drainage ways,
- <> may begin as ephemeral gullies that were left in the field untreated,
- <> may, over time, become partially stabilized by grass, weeds or woody vegetation,

Gully erosion is not calculated by the RUSLE2 program.

Streambank Erosion: The wearing away of streambanks by flowing water. The removal of soil from streambanks is typically caused by the direct action of stream flow and/or wind/wave action, typically occurring during periods of high flow. Streambank erosion:

<> is a natural process that generally increases when unprotected streambanks (e.g. no woody vegetation) are subject to the actions of flowing water and ice damage.

<> is a common occurrence on many Vermont river channels that are experiencing geomorphic adjustments

The soil loss from ephemeral gullies, gullies and streambank erosion areas can be estimated by calculating the volume of soil removed by erosion processes. The volume of soil loss can be multiplied by the typical unit weight of the soil (based on soil texture) which is eroded. Approximate soil unit weights are expressed below¹:

Soil Texture	Estimated Dry Density lb/ft ³
Gravel	110
Sand	105
Loamy Sand	100
Sandy Loam	100
Fine Sandy Loam	100
Sandy Clay Loam	90
Silt Loam	85
Silty Clay Loam	85
Silty Clay	85
Clay Loam	85
Organic	22

Procedure for estimating Ephemeral Soil Erosion:

The following formula will be used to calculate annual estimated ephemeral gully erosion:

$$\frac{\text{Ephemeral Gully Length} \times \text{Gully Average Width} \times \text{Gully Average Depth}}{2000} \times \text{Soil Weight (lbs/ft}^3\text{)} \times \text{Occurrences per Year} = \text{Estimated Soil Loss (Tons per Year)}$$

* Ephemeral gully erosion may reform multiple times per year, and under certain conditions it may not form in a given year. The voided volume which would be calculated after a runoff event is not necessarily representative of an annual rate, but is representative of only the specific event. This erosion can be calculated for individual storms and can be summed for a yearly estimate.

¹ Data from published soil surveys, laboratory data, and soil interpretation record are to be used where available. Parent materials, soil consistency, soil structure, pore space, soil texture, and coarse fragments all influence unit weight.

Procedure for estimating Gully Soil Erosion:

The following formula will be used to calculate annual estimated classic gully erosion:

$$\frac{\text{Gully Length} \times (\text{Average Width} \times \text{Average Depth} \times 0.5) \times \text{Soil Weight (lbs/ft}^3)}{2000} \div \text{Formation Years} = \text{Estimated Soil Loss Per Year (Tons)}$$

Procedure for estimating Streambank Soil Erosion (Direct Volume Method):

The following formula will be used to calculate annual estimated streambank erosion unless a field measurement procedure² is used:

$$\frac{\text{Stream Bank Length} \times \text{Eroding Bank Height} \times \text{Lateral Recession Rate (FT/YR)} \times \text{Soil Weight (lb)}}{2000} = \text{Estimated Soil Loss Per Year (Tons)}$$

** Eroding bank height is measured along the bank, not the vertical height of bank. Example: if vertical height of an eroding streambank is 5 feet, and the bank is on a 2:1 slope, the total eroding bank distance is 25 feet -- 1/2 (Base X Height).

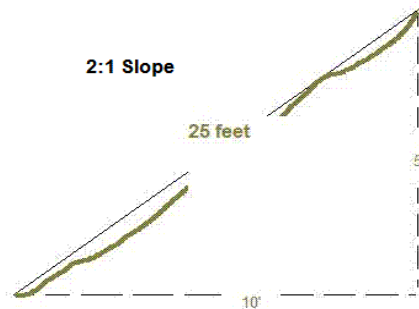

***The average annual recession rate is the thickness of soil eroded from a bank surface (perpendicular to the face) in an average year.

Stream bank erosion sometimes presents itself as a major occurrence in a given year, whereas the same bank may not erode significantly for a period of years if no major runoff events occur. Recession rates need to be calculated as an average of years when erosion does and does not occur. Recession rate is not calculated as the erosion occurring after a single event.

Use available resources to assist in the estimation of recession rate: use past and present aerial photography, old survey records, and any other information that helps to determine the bank condition at known times in the past. When such information is lacking or insufficient, field observations and professional judgement are needed to estimate recession rates.

It is often not possible to directly measure recession rates in the field. Therefore, the following table has been included which relates recession rates to narrative descriptions of banks eroding at different rates (Table from NRCS Wisconsin guidance).

Lateral Recession Rate (ft/yr)	Category	Description
0.01-0.05	Slight	Some bare bank but active erosion not readily apparent. Some rills but no vegetative overhang. No exposed tree roots.
0.06-0.2	Moderate	Bank is predominantly bare with some rills and vegetative overhang. Some exposed tree roots but no slumps or slips.
0.3-0.5	Severe	Bank is bare with rills and severe vegetative overhang. Many exposed tree roots and some fallen trees and slumps or slips. Some changes in cultural features such as fence corners missing and realignment of roads or trails. Channel cross section becomes U-shaped as opposed to V-shaped.
0.5+	Very Severe	Bank is bare with gullies and severe vegetative overhang. Many fallen trees, drains and culverts eroding out and changes in cultural features as above. Massive slips or washouts common. Channel cross section is U-shaped and stream course may be meandering.

2 The best way to quantify streambank erosion is to measure it directly in the field. The basic procedure in measuring streambank erosion is to survey, flag, or in some way fix a "before" image of the channel you are evaluating in order to establish the baseline condition. Changes due to erosion can then be monitored over time by going back to the study area and re-measuring from the fixed reference points. Channel cross-sections can be surveyed and plotted on a periodic basis to monitor change. Stakes or pins can be driven into channel banks flush with the surface. The amount of stake or pin exposed due to erosion is the amount of change at the streambank erosion site between your times of observation. The time required to monitor a site often precludes this method of data collection. The Direct Volume Method can be used to estimate streambank erosion at your site.

Acknowledgements: This Excel workbook was created as a planning tool for use by conservation planners. The basic format and content of the tool is a compilation of various similar tools, processes and procedures employed by NRCS in several states including: Indiana, Iowa, Kansas, Maryland, Michigan, Missouri, Nebraska, Oklahoma, South Dakota and Wisconsin. Some of the terminology in the 'Definitions' section of this Readme document closely mirrors these sources.

NRCS Streambank and Irrigation Ditch Erosion Estimator (Direct Volume Method)

Farmer / Cooperator Name:
 Tract Number:

Evaluated By:
 Evaluation Date:

<i>Property Owner</i>	<i>Eroding Strmbnk Reach #; or Ditch Side/Bottom</i>	<i>Eroding Bank or Ditch Length (Feet)</i>	<i>Eroding Bank Height; or Ditch Bottom Width* (Feet)</i>	<i>Area of Eroding Strmbank or Ditch (FT²)</i>	<i>Lateral or Ditch Bottom Recession Rate (Estimated) (FT / Year)</i>	<i>Estimated Volume (FT³) Eroded Annually</i>	<i>Soil Texture</i>	<i>Approximate Pounds of Soil per FT³</i>	<i>Estimated Soil Loss (Tons/Year)</i>	<i>Soil Total Phosphorus (ppm)</i>	<i>Estimated Phosphorus Loss (Pounds/Year)</i>
Turpin & City of Shullsburg	1 (Right)	1,137	3.8	4,321	0.35	1,512.2	Silt Loam	85	64.3	903	116
City of Shullsburg	2 (Right)	171	25.0	4,275	0.20	855.0	Silt Loam	85	36.3	1,789	130
City of Shullsburg	3 (Right)	431	4.9	2,112	0.45	950.4	Silt Loam	85	40.4	934	75
TOTAL						3317.6			141.0		322

Attachment #1 1

Water Quality Trading Operation and Maintenance Plan

Introduction:

The Water Quality Trading (WQT) Operation and Maintenance (O&M) Plan is meant to be a working document and should be updated as new trading practices are implemented. Currently, the Operation and Maintenance Plan revolves around the Best Management Practice (BMP) construction along the Shullsburg Branch. The attached *BMP Inspection Form* should be completed during annual inspections of BMPs and following major storm events. Inspection forms shall be retained for at least five (5) years to ensure compliance with the WQT Plan.

Publicly Owned BMP:

City representative to complete inspection form annually and following major storm events. The form will then be provided to the Maintenance Supervisor following inspection. The City will address maintenance issues identified during inspection within 30 days. Substantial maintenance issues may require an extended timeframe for generation of plans, specifications, and a public bid process to perform the work. Inspections and O&M activities shall be reported in the annual WQT Report sent to the DNR.

Privately Owned BMP:

City representative to complete inspection form annually and following major storm events. The form will then be provided to the Maintenance Supervisor following inspection. The City will address maintenance issues identified during inspection within 30 days. Substantial maintenance issues may require an extended timeframe for generation of plans, specifications, and a public bid process to perform the work. Maintenance expenses will be incurred by either by the City or Private Property Owner depending on agreement with the City. The Private Property Owner will be allowed to perform maintenance activities at the expense of the Private Property Owner. Inspections and O&M activities shall be reported in the annual WQT Report sent to the DNR.

Quality Assurance:

Riprap gradation and composition shall be provided for each source of material. Streambank shaping and riprap shall be installed per the Lafayette County Land Conservation Department and NRCS Standards. Contractors to supply rock that is approved by the NRCS and meets criteria in Wisconsin Construction Spec.9.

Installation:

- Staking provided by the Engineer.
- Do not place riprap over frozen or spongy subgrade surfaces.
- Place riprap as indicated on Construction Plans. Do not dump rip-rap over the bank.
- Blend riprap with existing bank.
- Spread soil out in a layer of less than 4" and seed down. Do not spread soil in wetlands.
- All disturbed areas and soil must be seeded and mulched.

Practice Registration:

The purpose of the "Water Quality Trading Management Practice Registration" form is to report to DNR that a management practice identified in the trading plan has been properly installed and is established and effective. This information will be used to track implementation progress, verify compliance and

perform audits, as necessary. A registration form should be submitted for every management practice that has been identified in the trading plan. If practices are established prior to trading plan submittal, registration forms may be submitted with the trading plan. Otherwise, registration forms should be submitted during the permit term as practices become effective or with the annual report. A blank *Water Quality Trading Management Practice Registration Form 3400-207* is attached and should be submitted following implementation of the trading practice.

Tracking Procedures:

The City will track credits used monthly. The City will report credit usage to the DNR on a monthly basis in the Discharge Monitoring Reports (DMRs). The annual report will summarize the 12 months of credit usage and credit generation. The City will report to DNR any concern that they have that may result in a need to modify the trade agreement and/or this trade plan. For example, a need to generate additional credits based on discharge.

Inspections/Maintenance Considerations:

- A *BMP Inspection Form* is attached.
 - Site: As noted on Construction Plans
 - Condition of BMP: Excellent; Good; Fair; or Poor
 - Maintenance Estimate: Provide an estimate for how long the maintenance will take to complete or a dollar value for completion. This will help determine if the City will perform the work or if the City will hire another entity to perform the work.
 - Date Completed: Following completion of the required maintenance, input the date of completion.
 - Comments: Provide the required maintenance activity along with any other useful information. If the cell provided is not large enough for Comments, write “See Back of Sheet” and provide comments on the reverse side of the Form.
- Following installation, inspect the disturbed areas closely over the next few months to ensure that seeding grows.
- BMPs may settle or shift especially after flooding events or freeze/thaw.
- May need to control weed and brush growth.
- Inspect stabilized areas as needed.
- At a minimum, inspect after major storm events.
- If a BMP has been damaged, repair it promptly to prevent a progressive failure.
- If repairs are needed repeatedly at a location, evaluate the site to determine if the original design conditions have changed.

Routine Maintenance Items that can be performed by City:

- Evaluate BMP condition
 - Reconstruct/replace BMPs that have settled, shifted, or washed out.
- Manage Vegetation
 - Remove invasive/noxious plants.
- Manage Garbage
 - Remove garbage and other debris that could otherwise impair the streambank stability.

Monthly Certification:

Each month, the City will certify that the BMPs are maintained and operating in a manner consistent with this Water Quality Trading Plan or provide a statement noting noncompliance with this Plan. The monthly Discharge Monitoring Report (DMR) will include the following statement as a certification of compliance when the Credit Generating Practice is operating in a manner consistent with the Plan:

“I certify that to the best of my knowledge that the management practices identified in the approved water quality trading plan as the source of phosphorus credits is installed, established and properly maintained.”

Annual Inspection:

An annual inspection of the BMPs will be performed by a licensed Professional Engineer to ensure that the BMPs are functioning as intended in order to meet the requirements of the WQT Plan.

Noncompliance:

The City will notify DNR by telephone call to DNR’s regional wastewater compliance engineer within 24 hours or next business day of becoming aware that phosphorus credits used or intended for use by City are not being generated as outlined in this Water Quality Trading Plan.

The City will submit a written notification within five days after the City recognizes that the phosphorus credits are not being generated as outlined in the Trading Plan. DNR may waive the requirement for submittal for a written notice within five days and instruct the City to submit the written notice with the next regularly scheduled monitoring report required by City’s WPDES Permit.

The written notification should include:

- Description of noncompliance and cause.
- Period of noncompliance including dates and times.
- Schedule for attaining compliance including time and steps toward compliance.
- Plan to prevent reoccurrence of the noncompliance.

Notification of Trade Agreement Termination:

If a trade agreement or the trading plan needs to be terminated during the permit term, the permittee should submit a Notice of Termination to the wastewater engineer/specialist to inform DNR of the termination. DNR staff should use this information to determine if a permit modification is required due to the termination, the termination will result in non-compliance, or other permit actions are required due to the termination. When credits are reduced or eliminated for any reason, the permittee is still required to meet their WQBELs without any grace period. To prevent noncompliance with WQBELs, changes to trading plans must be addressed before credits are lost. Modifying the permit/trading plan will require at least 180 days. A blank *Notification of Water Trade Agreement Termination Form 3400-209* is attached and should be submitted to DNR prior to practice termination, no later than the submittal date of the annual report.

BMP Inspection Form

Date _____

Inspector _____

Reason for Inspection _____

Reach	Condition of BMP	Required Maintenance	Maintenance Estimate (Time or Cost)	Date Completed	Comments
1 (Right)					
2 (Right)					
3 (Right)					

Notice: Pursuant to s. 283.84, Wis. Stats., this form must be completed by any WPDES permittee that is using water quality trading as a method of complying with a permit limitation. Failure to complete this form would not result in penalties. Personal information collected will be used for administrative purposes and may be provided to requesters to the extent required by Wisconsin's Open Records Law (ss. 19.31 - 19.39, Wis. Stats.).

Applicant Information					
Permittee Name		Permit Number WI-	Facility Site Number		
Facility Address			City	State	ZIP Code
Project Contact Name (if applicable)	Address		City	State	ZIP Code
Project Name					

Broker/Exchange Information (if applicable)		
Was a broker/exchange be used to facilitate trade? <input type="radio"/> Yes <input type="radio"/> No		
Broker/Exchange Organization Name		Contact Name
Address	Phone Number	Email

Trade Registration Information (Use a separate form for each trade agreement)					
Type	Trade Agreement Number	Practices Used to Generate Credits	Anticipated Load Reduction	Trade Ratio	Method of Quantification
<input type="radio"/> Urban NPS <input type="radio"/> Agricultural NPS <input type="radio"/> Other					
County	Closest Receiving Water Name		Land Parcel ID(s)	Parameter(s) being traded	

The preparer certifies all of the following:

- I have completed this document to the best of my knowledge and have not excluded pertinent information.
- I certify that the information in this document is true to the best of my knowledge.

Signature of Preparer	Date Signed
-----------------------	-------------

Authorized Representative Signature

I certify under penalty of law that this document and all attachments were prepared under my direction or supervision. Based on my inquiry of those persons directly responsible for gathering and entering the information, the information is, to the best of my knowledge and belief, accurate and complete. I am aware that there are significant penalties for submitting false information, including the possibility of fine and imprisonment for knowing violations.

Signature of Authorized Representative	Date Signed
--	-------------

Leave Blank – For Department Use Only		
Date Received		Trade Docket Number
Entered in Tracking System <input type="checkbox"/> Yes	Date Entered	Name of Department Reviewer

Notification of Water Trade Agreement Termination
 Form 3400-209 (1/14)

Notice: Pursuant to s. 283.84, Wis. Stats., and ch. NR 217 Wis. Adm. Code, this form must be completed by any WPDES permittee that is using water quality trading as a method of complying with a permit limitation. Failure to complete this form would not result in penalties. Personal information collected will be used for administrative purposes and may be provided to requesters to the extent required by Wisconsin's Open Records Law (ss. 19.31 - 19.39, Wis. Stats.).

Applicant Information					
Permittee Name		Permit Number WI-	Facility Site Number		
Facility Address			City	State	ZIP Code
Project Contact Name (if applicable)	Address		City	State	ZIP Code
Project Name					

Credit Generator Information		
Credit generator type (select all that apply):	<input type="checkbox"/> Permitted Discharge (non-MS4/CAFO) <input type="checkbox"/> Permitted MS4 <input type="checkbox"/> Permitted CAFO	<input type="checkbox"/> Urban nonpoint source discharge <input type="checkbox"/> Agricultural nonpoint source discharge <input type="checkbox"/> Other - Specify:
Trade Agreement number(s) to be terminated including affected land parcel ID(s):		

Amount of trading credit being terminated	Effective date of termination
Reason for termination	

Is this agreement being updated or replaced?	<input type="radio"/> Yes <input type="radio"/> No <input type="radio"/> Unsure
Will this termination result in non-compliance with the effective limit or other permit requirements?	<input type="radio"/> Yes; Name: _____ <input type="radio"/> No <input type="radio"/> Unsure

The preparer certifies all of the following:

- I am familiar with the specifications submitted for this application, and I believe all applicable items in this checklist have been addressed.
- I have completed this document to the best of my knowledge and have not excluded pertinent information.

Signature of Preparer	Date Signed
-----------------------	-------------

Authorized Representative Signature	
I certify under penalty of law that this document and all attachments were prepared under my direction or supervision. Based on my inquiry of those persons directly responsible for gathering and entering the information, the information is, to the best of my knowledge and belief, accurate and complete. I am aware that there are significant penalties for submitting false information, including the possibility of fine and imprisonment for knowing violations.	
Signature of Authorized Representative	Date Signed

Attachment #12

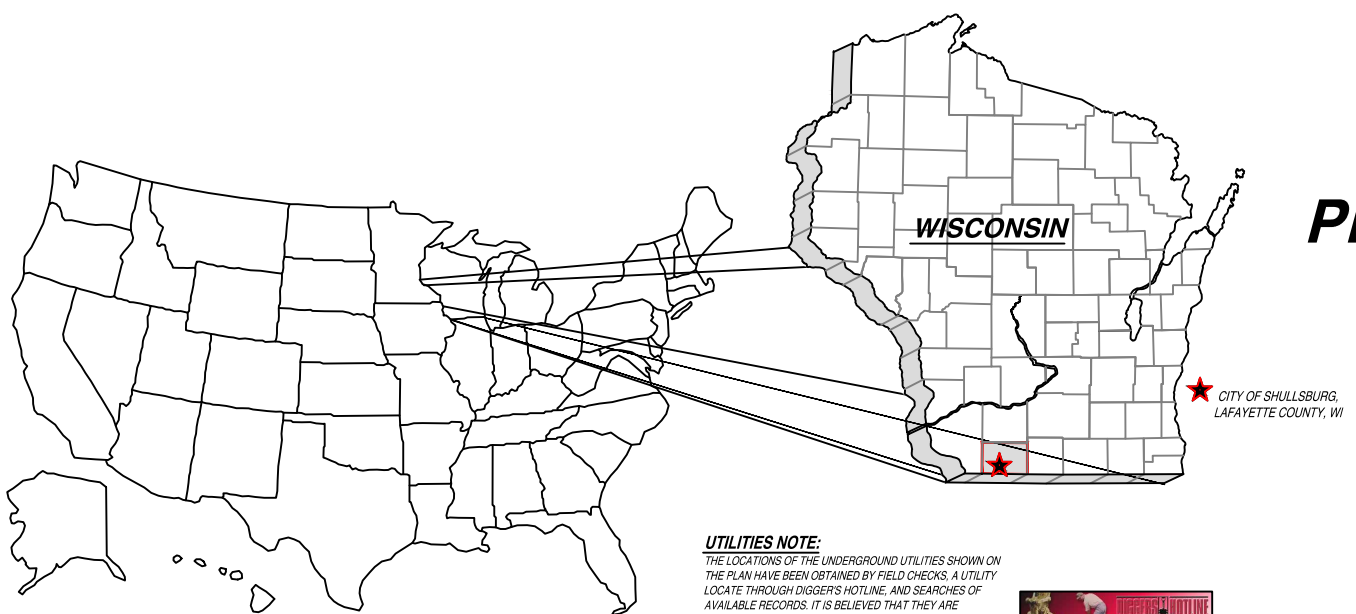

PROPOSED 2022 STREAMBANK IMPROVEMENTS - SHULLSBURG BRANCH

OWNER: CITY OF SHULLSBURG, WI

UTILITIES NOTE:

THE LOCATIONS OF THE UNDERGROUND UTILITIES SHOWN ON THE PLAN HAVE BEEN OBTAINED BY FIELD CHECKS. A UTILITY LOCATE THROUGH DIGGERS HOTLINE, AND SEARCHES OF AVAILABLE RECORDS. IT IS BELIEVED THAT THEY ARE ESSENTIALLY CORRECT, BUT THE SURVEYOR DOES NOT GUARANTEE THEIR ACCURACY OR COMPLETENESS. THE CONTRACTOR SHOULD VERIFY LOCATIONS WITH THE UTILITY COMPANIES AND THE "CITY OF SHULLSBURG" PRIOR TO STARTING ANY EXCAVATION.



DIGGER'S HOTLINE IS OPEN: 24 HOURS A DAY, 7 DAYS A WEEK, 365 DAYS A YEAR TO NOTIFY DIGGER'S HOTLINE OF YOUR INTENT TO DIG CALL: MILWAUKEE AREA: (414) 229-1181 TOLL FREE: (800) 242-8511 HEARING IMPAIRED (TDD): (800) 542-2289

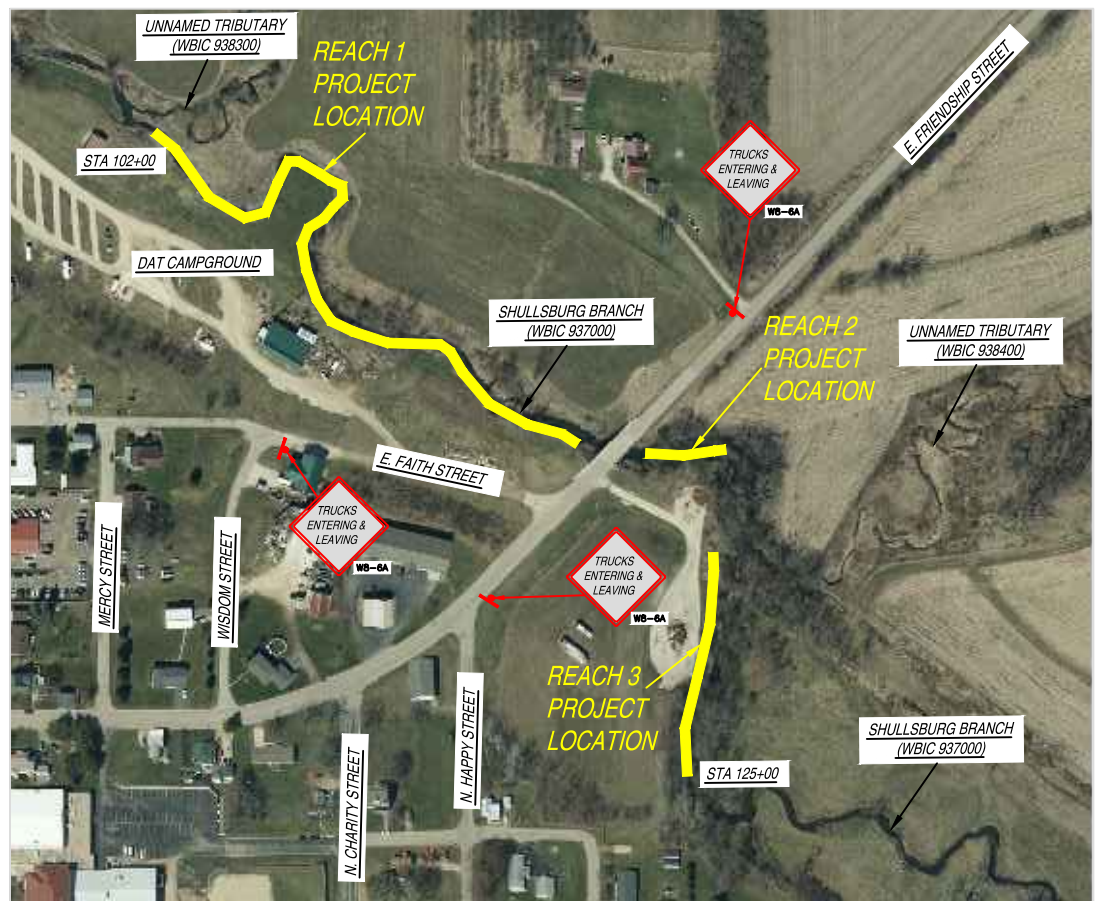

SHEET INDEX:

SHEET TITLE:	SHEET DESCRIPTION:	DATE OF ISSUE:	DATE OF REVISION:
G000	TITLE SHEET & PROJECT LOCATION MAP	JUNE 6, 2022	-
G001	LEGEND & GENERAL NOTES	JUNE 6, 2022	-
C101	PLAN VIEW - REACH 1	JUNE 6, 2022	-
C102	PLAN VIEW - REACHES 1 & 2	JUNE 6, 2022	-
C103	PLAN VIEW - REACH 3	JUNE 6, 2022	-
C201	DETAILS - EROSION CONTROL & NOTES	JUNE 6, 2022	-
C202	DETAILS - STREAM BANK	JUNE 6, 2022	-

PROJECT INFORMATION:

OWNER: CITY OF SHULLSBURG MS. MARSHA EINSWELLER - CLERK/ TREASURER 190 N. JUDGEMENT STREET P.O. BOX 580 SHULLSBURG, WI 53586 (608) 965-4424	SANITARY SEWER UTILITY: CITY OF SHULLSBURG MR. TOM KLEIBER 190 N. JUDGEMENT STREET P.O. BOX 580 SHULLSBURG, WI 53586 (608) 482-4636	WATER UTILITY: CITY OF SHULLSBURG MR. JOSÉ TREJO 190 N. JUDGEMENT STREET P.O. BOX 580 SHULLSBURG, WI 53586 (608) 482-4536	STREET AND STORM SEWER: CITY OF SHULLSBURG MR. DAVID TURPIN 190 N. JUDGEMENT STREET P.O. BOX 580 SHULLSBURG, WI 53586 (608) 482-2736	ELECTRIC UTILITY: CITY OF SHULLSBURG MR. MELVIN KREUL / MR. NICK DOYLE 190 N. JUDGEMENT STREET P.O. BOX 580 SHULLSBURG, WI 53586 MELVIN: (608) 482-4736 NICK: (608) 482-3997
NATURAL GAS UTILITY: WE ENERGIES MR. ADAM MARING N3025 14TH AVENUE MCNROE, WI 53506 (902)-262-8882 (OFFICE) (608)-426-1715 (CELL)	CABLE TELEVISION UTILITY: MEDIACOM, LLC MR. ROB MCDONALD 3033 ASBURY ROAD DUBUQUE, IA 52001 CELL: (563)-213-1123	TELEPHONE & CABLE TELEVISION: CENTURYLINK MR. DOUG MCGOWAN 135 N. BONSON PLATTVILLE, WI 53589 (608) 482-5377		

ENGINEER:
DELTA 3
EVERY ANGLE COVERED
PROFESSIONAL CIVIL, MECHANICAL, & STRUCTURAL ENGINEERING + ARCHITECTURE
GRADE SHEDDING + LAND DEVELOPMENT + PLANNING + CAD SERVICES
875 SOUTH CHESTNUT STREET PHONE: (608) 348-5305
PLATTSVILLE, WISCONSIN 53589
888 JACOB STREET PHONE: (563) 542-8005
DUBUQUE, IOWA 52001

FOR QUESTIONS REGARDING THIS PROJECT, PLEASE CONTACT:

MR. JORDAN FURE, E.I.T.
DELTA 3 ENGINEERING, INC.
TELEPHONE: (608) 348-5355

CONSENT STATEMENT
ALL RIGHTS RESERVED. AND NO REPRODUCTION WITHOUT CONSENT. ALL DRAWINGS, SPECS, REPORTS, DATA, AND OTHER DOCUMENTS CONTAINED ON THIS PLAN SHEET ARE CREATED BY AND FOR DELTA 3 ENGINEERING AND THEIR CLIENTS' USE. USE, REPRODUCTION, OR DISTRIBUTION OF ANY CONTENT HEREIN, IN ANY FORM, WHETHER PRINTED, ELECTRONIC, OR OTHERWISE, REQUIRES THE EXPLICIT WRITTEN PERMISSION OF THE OWNER.

PROPOSED 2022 STREAMBANK IMPROVEMENTS - SHULLSBURG BRANCH

CITY OF SHULLSBURG, WI
PROJECT LOCATION: SHULLSBURG BRANCH - EAST OF JUDGEMENT STREET
OWNER: CITY OF SHULLSBURG; 190 N. JUDGEMENT ST., P.O. BOX 580; SHULLSBURG, WI 53586

REVISIONS:

NO.	DATE	DESCRIPTION

AS-BUILT: BY:

PRELIMINARY

PROJECT NUMBER	D21-007
SHEET SCALE	NOT TO SCALE
DRAWN BY	C. COVIER
DATE ISSUED	JUNE 6, 2022
SHEET DESC.	TITLE SHEET & PROJECT LOCATION MAP

SHEET TITLE:
G000
SHEET NUMBER # 01 of 07

LEGEND

EX. CON. MANHOLE
EX. ECC. MANHOLE
EX. LIFT STATION
EX. CLEAN OUT
EX. FIRE HYDRANT
EX. WATER SERVICE
EX. WATER VALVE
EX. YARD HYDRANT
EX. CATCH BASIN
EX. STORM INLET
EX. NATURAL GAS VALVE
EX. NATURAL GAS METER
EX. POWER POLE
EX. LIGHT POLE
EX. WARNING SIREN
EX. TEL. PEDESTAL
EX. MAILBOX
EX. LP TANK
EX. SATELLITE DISH
EX. POST OR POLE
EX. STREET SIGN
EX. EVERGREEN TREE
EX. DECIDUOUS TREE
EX. TREE STUMP
EX. BUSH/SHRUB
EX. TREE/BRUSH LINE
EX. WINDMILL
EX. PARK BENCH
EX. BENCHMARK
SURVEY CONTROL POINT
EX. PROPERTY PIN
RIGHT-OF-WAY
PROPERTY LINE
EASEMENT
San. Lat.
EX. SAN. S. LATERAL
EX. 6" SAN. S. MAIN
EX. 8" SAN. S. MAIN
EX. 10" SAN. S. MAIN
EX. 12" SAN. S. MAIN
EX. 15" SAN. S. MAIN
EX. FLOW DIRECTION
EX. CAPPED SERVICE
EX. WATER SERVICE
EX. 4" WATER MAIN
EX. 6" WATER MAIN
EX. 8" WATER MAIN
EX. 10" WATER MAIN
EX. 12" WATER MAIN
EX. 15" STORM SEWER
EX. 12" STORM SEWER
EX. 18" STORM SEWER
EX. 24" STORM SEWER
EX. 30" STORM SEWER
EX. 36" STORM SEWER
EX. 48" STORM SEWER
EX. CURB AND GUTTER
EX. U.GRD N. GAS UTILITY
EX. U.GRD ELECTRIC UTILITY
EX. U.GRD CABLE TV UTILITY
EX. U.GRD TELEPHONE UTILITY
EX. FENCE
EX. TEMPORARY EASEMENT
EX. ESTIMATED DISTURBANCE LIMITS
EX. CONTOUR
EX. DRAINAGE SWALE
EX. SILT FENCE
EX. EROSION CONTROL
EX. SEDIMENT LOG
EX. PAVEMENT MARKING
EX. PAINTED TRAFFIC ARROW
EX. ADA PARKING DESIGNATION
EX. PARKING STALL COUNT
EX. RADIUS POINT/SIZE
EX. STA. ON CENTERLINE
EX. PROP. HANDICAP RAMP WITH
EX. DETECTABLE WARNING FIELD
EX. SOIL BORING LOCATION
EX. RIVER FLOW DIRECTION
EX. PROP. 4" DIA. SANITARY MANHOLE
EX. PROP. 5" DIA. SANITARY MANHOLE
EX. PROP. MANHOLE CHIMNEY
EX. REHABILITATION / TOP ADJUSTMENT
EX. PROP. SANITARY LIFT STATION
PROP. SANITARY SEWER LATERAL
PROP. 6" SANITARY SEWER MAIN
PROP. 8" SANITARY SEWER MAIN
PROP. 10" SANITARY SEWER MAIN
PROP. 12" SANITARY SEWER MAIN
PROP. 15" SANITARY SEWER MAIN
PROP. 18" SANITARY SEWER MAIN
PROP. CIPP LINER
PROP. FLOW DIRECTION
PROP. WATER SERVICE
PROP. <4" WATER MAIN
PROP. 4" WATER MAIN
PROP. 6" WATER MAIN
PROP. 8" WATER MAIN
PROP. 10" WATER MAIN
PROP. 12" WATER MAIN
PROP. 15" WATER MAIN
PROP. <12" STORM SEWER
PROP. 12" STORM SEWER
PROP. 15" STORM SEWER
PROP. 18" STORM SEWER
PROP. 24" STORM SEWER
PROP. 30" STORM SEWER
PROP. 36" STORM SEWER
PROP. 48" STORM SEWER
PROP. CURB AND GUTTER
PROP. CURB BACK OPENING
PROP. U.GRD GAS UTILITY
PROP. U.GRD ELECTRIC UTILITY
PROP. U.GRD CABLE TV UTILITY
PROP. U.GRD TELEPHONE UTILITY
PROP. U.GRD FIBER OPTIC UTILITY
PROP. OVERHEAD ELECTRIC
PROP. CROSSING OF N. GAS UTILITY
PROP. UTILITY POLE
PROP. LIGHT POLE
PROP. FENCE
TEMPORARY EASEMENT
CONSTRUCTION EASEMENT
ESTIMATED DISTURBANCE LIMITS
PROP. CONTOUR
PROP. DRAINAGE SWALE
PROP. SILT FENCE
PROP. EROSION CONTROL
SEDIMENT LOG
PROP. PAVEMENT MARKING
PAINTED TRAFFIC ARROW
ADA PARKING DESIGNATION
PARKING STALL COUNT
RADIUS POINT/SIZE
STA. ON CENTERLINE
PROP. HANDICAP RAMP WITH
DETECTABLE WARNING FIELD
SOIL BORING LOCATION
RIVER FLOW DIRECTION
PROP. 4" DIA. SANITARY MANHOLE
PROP. 5" DIA. SANITARY MANHOLE
PROP. MANHOLE CHIMNEY
REHABILITATION / TOP ADJUSTMENT
PROP. SANITARY LIFT STATION
PROP. TYPE "X" CURB & GUTTER
PROP. REVERSE-PITCH CURB & GUTTER
PROP. HOT MIX ASPHALT PAVEMENT (DRIVEWAY)
PROP. 4" CONCRETE SIDEWALK
PROP. 6" CONCRETE PAVEMENT
PROP. 8" CONCRETE PAVEMENT
PROP. GRAVEL SHOULDER / DRIVEWAY
EROSION MATTING (MILD SLOPES)
EROSION MATTING (STEEP SLOPES)
PROP. REGRADING AND LANDSCAPING
PROP. RIP-RAP
PROP. STORM STRUCTURES - PROFILE
PROP. STORM PIPE (RCP) - PROFILE
PROP. STORM PIPE (CMP OR HDPE) - PROFILE
PROP. SANITARY STRUCTURE - PROFILE
PROP. WATER MAIN PIPE - PROFILE
PROP. CLAY LINER - PROFILE
PROP. SANITARY SEWER FORCE MAIN - PROFILE
PROP. SPOT REPAIR - PROFILE / PLAN VIEW
PROP. CASING PIPE - PROFILE
PROP. CLEARING AND GRUBBING
PROP. BUILDING REMOVAL
PROP. SIDEWALK REMOVAL
PROP. PRESSURE-REDUCING VALVE STATION
PROP. FIRE HYDRANT
PROP. WATER SERVICE
PROP. WATER SERVICE W/ VALVE BOX SLEEVE
PROP. WATER VALVE
PROP. WATER BEND - HORIZONTAL
PROP. WATER BEND - VERTICAL
PROP. WATER BEND <5"
PROP. WATER TEE
PROP. WATER CROSS
PROP. WATER REDUCER
PROP. MJ PLUG
PROP. 4" DIA. STORM MANHOLE
PROP. 5" DIA. STORM MANHOLE
PROP. INLET
PROP. 4" DIA. INLET
PROP. 6" DIA. INLET
PROP. 4" DIA. CATCH BASIN- W/ 2'X3' CASTING
PROP. 5" DIA. CATCH BASIN- W/ 2'X3' CASTING
PROP. 6" DIA. CATCH BASIN- W/ 2'X3' CASTING
PROP. 4'X6' CATCH BASIN W/ 2'X3' CASTING
PROP. CURB OPENING CASTING
PROP. 2'X3' CATCH BASIN
PROP. ADJUSTED CATCH BASIN TOP
PROP. WISDOT TYPE 8 INLET
PROP. WISDOT TYPE 9 INLET
PROP. CMP ENDWALL
PROP. RCP ENDWALL

KEY NOTES

100 PROPOSED SILT FENCE FOR EROSION CONTROL.
101 PROPOSED SEDIMENT LOG FOR EROSION CONTROL.
102 PROPOSED TRACKING PAD FOR EROSION CONTROL.
103 RE-GRADE YARD/DITCH LINE (MIN. SLOPE 1.0%).
104 PROPOSED EROSION MAT CLASS 1, TYPE 'B'.
105 INSTALL TYPE 'D' INLET PROTECTION.
106 PROPOSED MAIL BOX RELOCATION.
107 ITEM TO REMAIN.
108 CONTRACTOR TO REMOVE ITEM.
109 PROPOSED TURBIDITY BARRIER (TYP.) (SEE DETAIL - SHEET C203).
110 PROPOSED EROSION CONTROL REVEGETATIVE MAT (ECRM).
111 REMOVE AND SALVAGE TO OWNER IN PRE-CONSTRUCTION CONDITION.
112 REINSTALL STREET SIGN AS PER OWNER/WISDOT REQUIREMENTS.
113 PROPOSED STREAM BANK GRADING (2:1 SLOPE) WITH RIP-RAP TO TOP OF BANK (SEE DETAIL - SHEET C202).
114 PROPOSED STREAM BANK GRADING (6:1 SLOPE)(SEE DETAIL - SHEET C202).
200 PROPOSED SANITARY SEWER [SIZE].
201 NEW SANITARY SEWER LATERAL [SIZE].
202 REPLACE EXISTING SANITARY SEWER LATERAL.
203 RECONNECT EXISTING SANITARY SEWER LATERAL.
204 CONNECTION TO EXISTING SANITARY SEWER PIPE/STRUCTURE.
205 REMOVE EXISTING SANITARY SEWER PIPE /STRUCTURE.
206 REHABILITATE SANITARY MANHOLE; SEE TABLE 'B'.
207 SANITARY SEWER SPOT REPAIR.
208 ABANDON AND CAP EXISTING SANITARY SEWER.
209 ABANDON EXISTING SANITARY SEWER LATERAL.
210 CONTRACTOR TO FIELD VERIFY SANITARY SEWER LATERAL LOCATION/ACTIVITY AND REPLACE ACCORDING TO ENGINEER.
300 PROPOSED WATER MAIN [SIZE].
301 NEW WATER SERVICE [SIZE].
302 REPLACE EXISTING WATER SERVICE WITH 1" WATER SERVICE.
303 RECONNECT EXISTING WATER SERVICE.
304 DIRECTIONAL DRILL PROPOSED WATER SERVICE.
305 CONNECTION TO EXISTING WATER MAIN.
306 EXISTING HYDRANT TO BE REMOVED AND SALVAGED TO OWNER.
307 REMOVE EXISTING WATER MAIN VALVE BOX/STRUCTURE.
308 ADJUST EXISTING WATER MAIN VALVE BOX.
309 ABANDON, DRAIN, & CAP EXISTING WATER MAIN.
310 ABANDON EXISTING WATER SERVICE.
311 CONTRACTOR TO FIELD VERIFY WATER SERVICE LOCATION/ACTIVITY AND REPLACE ACCORDING TO ENGINEER.
400 PROPOSED STORM SEWER [SIZE].
401 CONNECT EXISTING ROOF DRAIN TO CURB OPENING
402 CONNECTION TO EXISTING STORM SEWER PIPE/STRUCTURE.
403 REMOVE EXISTING STORM SEWER PIPE/STRUCTURE.
404 ABANDON & CAP EXISTING STORM SEWER.
405 ADJUST EXISTING STORM STRUCTURE.
500 TREE & STUMP TO BE REMOVED (LESS THEN 12")
501 TREE & STUMP TO BE REMOVED (12" & GREATER)
502 SHRUB TO BE REMOVED.
503 CLEAR AND GRUB BRUSH LINE AS NECESSARY TO COMPLETE CONSTRUCTION. ALL CLEARING TO BE VERIFIED BY PROJECT ENGINEER.
504 REMOVE AND REINSTALL/REPLACE EXISTING LANDSCAPING, FENCE, RETAINING WALL, ETC. (IF NECESSARY).
505 REMOVE EXISTING LANDSCAPING, FENCE, RETAINING WALL, ETC.
506 POLE/PEDESTAL TO BE SECURED BY UTILITY COMPANY DURING CONSTRUCTION.
507 POLE TO BE RELOCATED BY UTILITY COMPANY.
508 GUY WIRE TO BE RELOCATED BY UTILITY COMPANY.
509 PEDESTAL TO BE RELOCATED BY UTILITY COMPANY.
510 UTILITY CONFLICT - TO BE RELOCATED/ADJUSTED BY UTILITY COMPANY.
511 POTENTIAL UTILITY CONFLICT - VERIFY WITH UTILITY COMPANY.
512 CAUTION! - UTILITY CROSSING.
600 REMOVE EXISTING CURB & GUTTER.
601 PROPOSED 24" CONCRETE CURB & GUTTER.
602 PROPOSED 30" CONCRETE CURB & GUTTER.
603 PROPOSED 36" CONCRETE CURB & GUTTER.
604 MATCH TO EXISTING CURB & GUTTER.
605 PROVIDE TYPE 'X' CURB.
606 PROVIDE REVERSE-PITCH CURB & GUTTER.
607 PROVIDE CURB TAPER.
608 REMOVE ASPHALT/CONCRETE/WALL/STEPS.
609 PROPOSED 4" CONCRETE SIDEWALK.
610 PROPOSED 6" CONCRETE SIDEWALK/DRIVEWAY.
611 PROPOSED 6" CONCRETE PAVEMENT.
612 PROPOSED 8" CONCRETE PAVEMENT.
613 PROPOSED CONCRETE STEPS. STEP RISE HEIGHT AND STEP TREAD DEPTH SHALL MEET APPLICABLE BUILDING CODES. CONTRACTOR SHALL CONFIRM REQUIRED NUMBER OF STEPS WITH PROJECT ENGINEER PRIOR TO INSTALL.
614 PROPOSED 2" GRAVEL SHOULDER.
615 REGRADE EXISTING GRAVEL.
616 PROPOSED GRAVEL DRIVEWAY.
617 REMOVE & REPLACE GRAVEL DRIVEWAY.

NOTES:

TRAFFIC CONTROL NOTE:

ALL CONTRACTORS MUST CONFORM TO THE MANUAL OF UNIFORM TRAFFIC CONTROL DEVICES (MUTCD) AND THE REQUIREMENTS OF THE WISCONSIN DEPARTMENT OF TRANSPORTATION. ONE LANE OF TRAFFIC MUST REMAIN OPEN DURING AND AFTER ALL CONSTRUCTION ACTIVITIES FOR EMERGENCY VEHICLE ACCESS.

STREET SIGN NOTE:

CONTRACTOR WILL BE RESPONSIBLE FOR REMOVING, STORING, AND RESETTING ALL PERMANENT SIGNS. CONTRACTOR IS RESPONSIBLE FOR PROTECTING ALL EXISTING SIGNS UNTIL REMOVED. CONTRACTOR IS RESPONSIBLE FOR ANY AND ALL TEMPORARY SIGNS THAT MAY BE REQUIRED.

TRAFFIC SIGN NOTE:

CONTRACTOR TO PROVIDE TEMPORARY TRAFFIC SIGNS FOR ANY TRAFFIC SIGNS DISTURBED DURING CONSTRUCTION. ALL DISTURBED TRAFFIC SIGNS MUST BE REPLACED AND INSTALLED AS PER LOCAL REGULATIONS AT THE COMPLETION OF THE PROJECT.

EROSION CONTROL NOTE:

CONTRACTOR TO INSTALL BACKFILL MATERIAL INTO THE EXCAVATED TRENCH AS SOON AS POSSIBLE TO IMPLEMENT EROSION CONTROL.

PROPERTY LINE AND RIGHT-OF-WAY NOTE:

ALL RIGHT-OF-WAYS AND PROPERTY LINES SHOWN ARE APPROXIMATE AND FOR ILLUSTRATIVE PURPOSES ONLY. A PROPERTY SURVEY PERFORMED BY A PROFESSIONAL LAND SURVEYOR SHOULD BE COMPLETED TO DETERMINE THE ACTUAL PROPERTY LINE AND RIGHT-OF-WAY LOCATIONS.

MAILBOX RELOCATION NOTE:

CONTRACTOR TO RELOCATE EXISTING MAILBOXES DURING CONSTRUCTION (COORDINATE AND VERIFY WITH LOCAL POSTAL SERVICE ON LOCATION). RESET BEHIND CURB AND GUTTER OR SHOULDER ACCORDING TO THE REQUIREMENTS OF THE LOCAL POSTMASTER UPON COMPLETION OF STREET CONSTRUCTION.

TREE TRIMMING NOTE:

CONTRACTOR TO PROPERLY TRIM ALL TREE BRANCHES, ROOTS, AND BUSHES DISTURBED DUE TO CONSTRUCTION.

TREE REMOVAL NOTE:

CONTRACTOR TO CONTACT ENGINEER OR CITY OF SHULLSBURG FOR VERIFICATION PRIOR TO ANY TREE REMOVAL.

SAW CUT NOTE:

CONTRACTOR TO PROVIDE FULL DEPTH SAW CUTS AND REPLACE PAVEMENT.

UTILITIES' NOTE:

THE LOCATIONS OF THE UNDERGROUND UTILITIES SHOWN ON THE PLAN HAVE BEEN OBTAINED BY FIELD CHECKS, A UTILITY LOCATE THROUGH DIGGER'S HOTLINE, AND SEARCHES OF AVAILABLE RECORDS. IT IS BELIEVED THAT THEY ARE ESSENTIALLY CORRECT, BUT THE SURVEYOR DOES NOT GUARANTEE THEIR ACCURACY OR COMPLETENESS. THE CONTRACTOR SHOULD VERIFY LOCATIONS W/ THE UTILITY COMPANIES AND THE CITY OF SHULLSBURG PRIOR TO STARTING ANY EXCAVATION.

TRAFFIC RESTORATION NOTE:

CONTRACTOR WILL BE RESPONSIBLE FOR REPLACEMENT OF ALL DISTURBED PROJECT AREA COMPONENTS INCLUDING, BUT NOT LIMITED TO, EXISTING CONCRETE, BITUMINOUS PAVEMENT, GRAVEL, CULVERTS, WATER AND SANITARY SEWER SYSTEM COMPONENTS, STORM SEWER SYSTEM COMPONENTS, TREES, LAWN ORNAMENTS, FENCING, YARD LANDSCAPING, RETAINING WALLS, MAILBOXES, AND LANDSCAPE AREAS.

PROPERTY DAMAGES:

THE CONTRACTOR IS RESPONSIBLE FOR THE PRESERVATION OF ADJACENT PROPERTY AND FOR ANY DAMAGE TO THE SITE OR TO ADJACENT PROPERTY INCIDENTAL TO THE CONSTRUCTION ACTIVITIES. AFTER THE COMPLETION OF CONSTRUCTION, ANY AREAS ADJACENT TO THE CONSTRUCTION SITE DAMAGED BY THE CONTRACTOR DURING EXECUTION OF THE CONTRACT SHALL BE RESTORED TO MATCH THE PRECONSTRUCTION CONDITIONS.

GENERAL NOTES:

- CONTRACTOR SHALL REPAIR ALL DRIVEWAYS, FENCES, AND FIELD ROADS DAMAGED DUE TO CONSTRUCTION ACTIVITIES.
- CONTRACTOR TO INSTALL EROSION CONTROL AND TURBIDITY BARRIER PRIOR TO COMMENCING CONSTRUCTION.
- CONTRACTOR TO CLEAR AND GRUB ALL PROPOSED GRADING LOCATIONS.
- SOIL SPREAD WITHIN THE FLOOD PLAIN AREA SHALL NOT EXCEED FOUR INCHES (4") OF DEPTH AND SHALL NOT BE DEPOSITED INTO WETLANDS.
- CONTRACTOR SHALL NOT REMOVE TREES, SOIL, ROCK, AND THE LIKE FROM THE SITE WITHOUT CONSENT OF THE OWNER.
- CONTRACTOR TO INSTALL EXISTING DRAIN TILES THROUGH PROPOSED GRADING AND RIP-RAP.
- CONTRACTOR TO RESTORE/LANDSCAPE ALL DISTURBED AREAS.

DISCIPLINE DESIGNATORS

DISCIPLINE	DESIGNATION
REMOVAL	R
GENERAL	G
CIVIL	C
LANDSCAPE	L
AQUATIC	AQ
ARCHITECTURAL	A
STRUCTURAL	S
ELECTRICAL	E
INSTRUMENTATION/CONTROLS	N
PROCESS	D
PLUMBING	P
HVAC /MECHANICAL	M

TYPE DESIGNATION

TYPE	DESIGNATION
NOTES & SCHEDULES	0
PLANS	1
ELEVATIONS & DETAILS	2
CROSS-SECTIONS	3
DIAGRAMS	4

DRAWING SHEET DESIGNATION

C102

- DRAWING NUMBER
- DRAWING SHEET DESIGNATION
- DISCIPLINE DESIGNATION (MAY HAVE MULTIPLE)

SHEET NUMBER IDENTIFICATION

ENGINEER:
DELTA 3
PROFESSIONAL CIVIL, MUNICIPAL, & STRUCTURAL ENGINEERING • PROFESSIONAL GRADING, LAYOUT, DEVELOPMENT, PLANNING & CAD SERVICES
875 SOUTH CHESTNUT STREET PHONE: (608) 348-5555
PLATEVILLE, WISCONSIN 53153
888 JOHNSON STREET PHONE: (563) 542-9005
DUBUQUE, IOWA 52001

FOR QUESTIONS REGARDING THIS PROJECT, PLEASE CONTACT:
MR. JORDAN FURE, E.I.T.
DELTA 3 ENGINEERING, INC.
TELEPHONE: (608) 348-5355

CONSENT STATEMENT
ALL RIGHTS RESERVED. AND NO REPRODUCTION WITHOUT CONSENT. ALL DRAWINGS, SPECS, REPORTS, DATA, AND OTHER DOCUMENTS CONTAINED ON THIS PLAN SHEET ARE CREATED BY AND FOR DELTA 3 ENGINEERING AND THEIR CLIENTS. USE, REPRODUCTION, OR DISTRIBUTION OF ANY CONTENT HEREIN, IN ANY FORM, WHETHER PRINTED, ELECTRONIC, OR OTHERWISE, REQUIRES THE EXPLICIT WRITTEN PERMISSION OF THE OWNER.

PROPOSED 2022 STREAMBANK IMPROVEMENTS - SHULLSBURG BRANCH
CITY OF SHULLSBURG, WI
PROJECT LOCATION: SHULLSBURG BRANCH - EAST OF JUDGMENT STREET
OWNER: CITY OF SHULLSBURG, 190 N. JUDGEMENT ST., P.O. BOX 680, SHULLSBURG, WI 53598

REVISIONS:

NO.	DATE	DESCRIPTION

AS-BUILT: BY:

PRELIMINARY

PROJECT NUMBER	DATE
D21-007	

SHEET SCALE	NOT TO SCALE

DRAWN BY	C. COVIER

DATE ISSUED	JUNE 6, 2022

SHEET DESC.	LEGEND & GENERAL NOTES

SHEET TITLE:
G001
SHEET NUMBER # 02 of 07

GENERAL NOTES:

1. CONTRACTOR SHALL REPAIR ALL DRIVEWAYS AND ACCESS ROADS DAMAGED DUE TO CONSTRUCTION ACTIVITIES.
2. CONTRACTOR TO INSTALL EROSION CONTROL AND TURBIDITY BARRIER PRIOR TO COMMENCING CONSTRUCTION.
3. CONTRACTOR TO CLEAR AND GRUB ALL PROPOSED GRADING LOCATIONS. SOIL SPREAD WITHIN THE FLOOD PLAIN AREA SHALL NOT EXCEED FOUR INCHES (4") OF DEPTH AND SHALL NOT BE DEPOSITED INTO WETLANDS.
4. CONTRACTOR SHALL NOT REMOVE TREES, SOIL, ROCK, AND THE LIKE FROM THE SITE WITHOUT CONSENT OF THE OWNER.
5. CONTRACTOR TO INSTALL EXISTING DRAIN TILES THROUGH PROPOSED GRADING AND RIP-RAP.
6. CONTRACTOR TO RESTORE LANDSCAPE ALL DISTURBED AREAS.

KEY NOTES 100:

- 107 ITEM TO REMAIN.
- 109 PROPOSED TURBIDITY BARRIER (TYP.); SEE DETAIL - SHEET C202.
- 113 PROPOSED STREAM BANK GRADING (2:1 SLOPE) WITH RIP-RAP TO TOP OF BANK; SEE DETAIL - SHEET C202.
- 114 PROPOSED STREAM BANK GRADING (6:1 SLOPE) (SEE DETAIL - SHEET C201).
- 503 CLEAR AND GRUB BRUSH LINE AS NECESSARY TO COMPLETE CONSTRUCTION. ALL CLEARING TO BE VERIFIED BY PROJECT ENGINEER.



SCALE: 1"=20' (24"x36")

ENGINEER:
DELTA 3
 EVERY ANGLE COVERED
 PROFESSIONAL CIVIL, MECHANICAL, & STRUCTURAL ENGINEERING - ARCHITECTURE
 GRANT WRITING - LAND DEVELOPMENT - PLANNING & CAD SERVICES
 875 SOUTH CHESTNUT STREET PHONE: (608) 348-5355
 PLATEVILLE, WISCONSIN 53158
 888 JOHNSON STREET PHONE: (363) 542-9005
 DUBLUQUE, IOWA 52001

FOR QUESTIONS REGARDING THIS PROJECT, PLEASE CONTACT:
MR. JORDAN FURE, E.I.T.
 DELTA 3 ENGINEERING, INC.
 TELEPHONE: (608) 348-5355

CONSENT STATEMENT
 ALL RIGHTS RESERVED. AND NO REPRODUCTION WITHOUT CONSENT. ALL DRAWINGS, SPECS, REPORTS, DATA, AND OTHER DOCUMENTS CONTAINED ON THIS PLAN SHEET ARE CREATED BY AND FOR DELTA 3 ENGINEERING AND THEIR CLIENTS' USE. USE, REPRODUCTION, OR DISTRIBUTION OF ANY CONTENT HEREIN, IN ANY FORM, WHETHER PRINTED, ELECTRONIC, OR OTHERWISE, REQUIRES THE EXPLICIT WRITTEN PERMISSION OF THE OWNER.



PROPOSED 2022 STREAMBANK IMPROVEMENTS - SHULLSBURG BRANCH
CITY OF SHULLSBURG, WI
 PROJECT LOCATION: SHULLSBURG BRANCH - EAST OF JUDGEMENT STREET
 OWNER: CITY OF SHULLSBURG, 190 N. JUDGEMENT ST., P.O. BOX 560; SHULLSBURG, WI 53586

NO.	DATE	DESCRIPTION

AS-BUILT: BY:

PROJECT NUMBER	D21-007
SHEET SCALE	SEE BAR SCALE
DRAWN BY	JORDAN FURE
DATE ISSUED	JUNE 6, 2022
SHEET DESC.	DESCRIPTION

SHEET TITLE:
C101
 SHEET NUMBER # 03 of 07

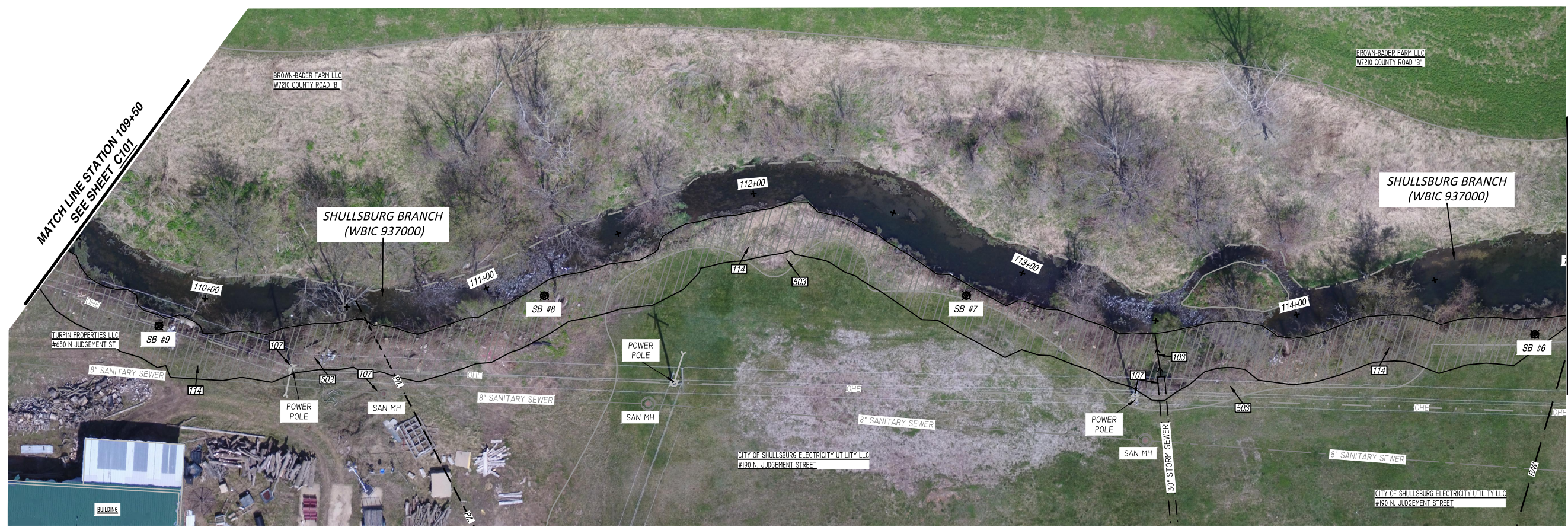

ENGINEER:
DELTA 3
EVERY ANGLE COVERED
 PROFESSIONAL CIVIL, MECHANICAL, & STRUCTURAL ENGINEERING • ARCHITECTURE
 GRANT WRITING • LAND DEVELOPMENT • PLANNING & CAD SERVICES
 875 SOUTH CHESTNUT STREET PHONE: (608) 348-5355
 PLATEVILLE, WISCONSIN 53181
 888 JACKSON STREET PHONE: (563) 542-9005
 DUBUQUE, IOWA 52001

FOR QUESTIONS REGARDING THIS PROJECT, PLEASE CONTACT:
MR. JORDAN FURE, E.I.T.
 DELTA 3 ENGINEERING, INC.
 TELEPHONE: (608) 348-5355

CONSENT STATEMENT
 ALL RIGHTS RESERVED. AND NO REPRODUCTION WITHOUT CONSENT. ALL DRAWINGS, SPECS, REPORTS, DATA, AND OTHER DOCUMENTS CONTAINED ON THIS PLAN SHEET ARE CREATED BY AND FOR DELTA 3 ENGINEERING AND THEIR CLIENTS' USE. USE, REPRODUCTION, OR DISTRIBUTION OF ANY CONTENT HEREIN, IN ANY FORM, WHETHER PRINTED, ELECTRONIC, OR OTHERWISE, REQUIRES THE EXPLICIT WRITTEN PERMISSION OF THE OWNER.

PROPOSED 2022 STREAMBANK IMPROVEMENTS - SHULLSBURG BRANCH
CITY OF SHULLSBURG, WI
 PROJECT LOCATION: SHULLSBURG BRANCH - EAST OF JUDGEMENT STREET
 OWNER: CITY OF SHULLSBURG, 190 N. JUDGEMENT ST., P.O. BOX 680, SHULLSBURG, WI 53586

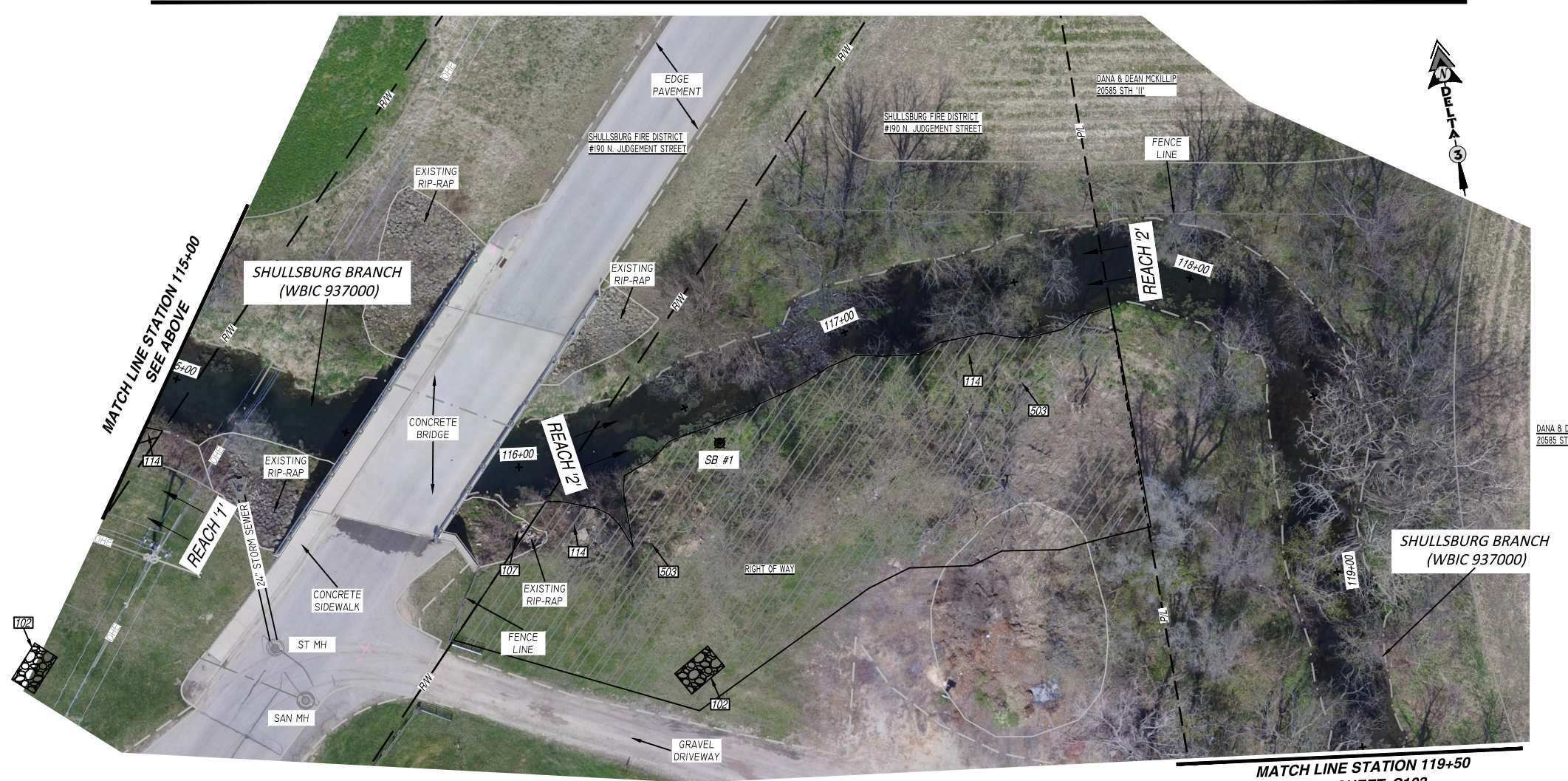

KEY NOTES 100:

- 102 PROPOSED TRACKING PAD FOR EROSION CONTROL.
- 103 RE-GRADE YARD/DITCH LINE (MIN. SLOPE 1.0%).
- 107 ITEM TO REMAIN.
- 114 PROPOSED STREAM BANK GRADING (6:1 SLOPE)(SEE DETAIL - SHEET C201).
- 503 CLEAR AND GRUB BRUSH LINE AS NECESSARY TO COMPLETE CONSTRUCTION. ALL CLEARING TO BE VERIFIED BY PROJECT ENGINEER.

GENERAL NOTES:

1. CONTRACTOR SHALL REPAIR ALL DRIVEWAYS AND ACCESS ROADS DAMAGED DUE TO CONSTRUCTION ACTIVITIES.
2. CONTRACTOR TO INSTALL EROSION CONTROL AND TURBIDITY BARRIER PRIOR TO COMMENCING CONSTRUCTION.
3. CONTRACTOR TO CLEAR AND GRUB ALL PROPOSED GRADING LOCATIONS.
4. SOIL SPREAD WITHIN THE FLOOD PLAIN AREA SHALL NOT EXCEED FOUR INCHES (4") OF DEPTH AND SHALL NOT BE DEPOSITED INTO WETLANDS.
5. CONTRACTOR SHALL NOT REMOVE TREES, SOIL, ROCK, AND THE LIKE FROM THE SITE WITHOUT CONSENT OF THE OWNER.
6. CONTRACTOR TO INSTALL EXISTING DRAIN TILES THROUGH PROPOSED GRADING AND RIP-RAP.
7. CONTRACTOR TO RESTORE/LANDSCAPE ALL DISTURBED AREAS.

REVISIONS:		
NO.	DATE	DESCRIPTION

PRELIMINARY	
PROJECT NUMBER	D21-007
SHEET SCALE	SEE BAR SCALE
DRAWN BY	JORDAN FURE
DATE ISSUED	JUNE 6, 2022
SHEET DESC.	DESCRIPTION

SHEET TITLE:
C102
 SHEET NUMBER # 04 of 07

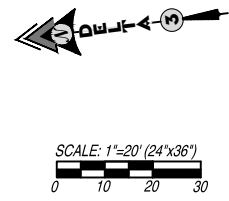

FOR QUESTIONS REGARDING THIS PROJECT, PLEASE CONTACT:
MR. JORDAN FURE, E.I.T.
 DELTA 3 ENGINEERING, INC.
 TELEPHONE: (608) 348-5355

CONSENT STATEMENT
 ALL RIGHTS RESERVED. AND NO REPRODUCTION WITHOUT CONSENT. ALL DRAWINGS, SPECS, REPORTS, DATA, AND OTHER DOCUMENTS CONTAINED ON THIS PLAN SHEET ARE CREATED BY AND FOR DELTA 3 ENGINEERING AND THEIR CLIENTS' USE. USE, REPRODUCTION, OR DISTRIBUTION OF ANY CONTENT HEREIN, IN ANY FORM, WHETHER PRINTED, ELECTRONIC, OR OTHERWISE, REQUIRES THE EXPLICIT WRITTEN PERMISSION OF THE OWNER.

KEY NOTES 100 :

- 103 RE-GRADE YARD/DITCH LINE (MIN. SLOPE 1.0%).
- 107 ITEM TO REMAIN.
- 114 PROPOSED STREAM BANK GRADING (6:1 SLOPE)(SEE DETAIL - SHEET C201).
- 503 CLEAR AND GRUB BRUSH LINE AS NECESSARY TO COMPLETE CONSTRUCTION. ALL CLEARING TO BE VERIFIED BY PROJECT ENGINEER.

GENERAL NOTES:

1. CONTRACTOR SHALL REPAIR ALL DRIVEWAYS AND ACCESS ROADS DAMAGED DUE TO CONSTRUCTION ACTIVITIES.
2. CONTRACTOR TO INSTALL EROSION CONTROL AND TURBIDITY BARRIER PRIOR TO COMMENCING CONSTRUCTION.
3. CONTRACTOR TO CLEAR AND GRUB ALL PROPOSED GRADING LOCATIONS. SOIL SPREAD WITHIN THE FLOOD PLAIN AREA SHALL NOT EXCEED FOUR INCHES (4") OF DEPTH AND SHALL NOT BE DEPOSITED INTO WETLANDS.
5. CONTRACTOR SHALL NOT REMOVE TREES, SOIL, ROCK, AND THE LIKE FROM THE SITE WITHOUT CONSENT OF THE OWNER.
6. CONTRACTOR TO INSTALL EXISTING DRAIN TILES THROUGH PROPOSED GRADING AND RIP-RAP.
7. CONTRACTOR TO RESTORE LANDSCAPE ALL DISTURBED AREAS.

MATCH LINE STATION 119+50
SEE SHEET C102

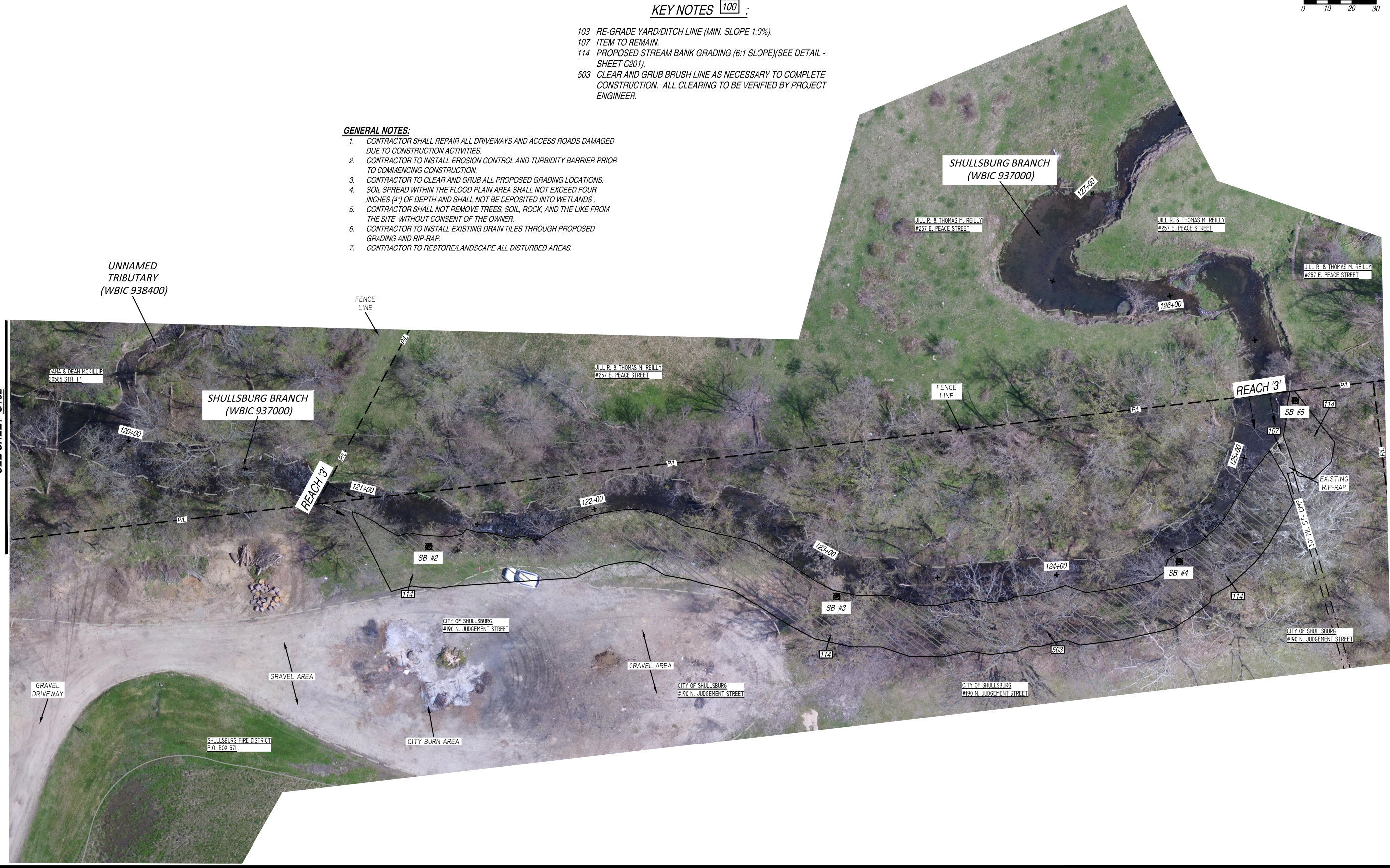

PROPOSED 2022 STREAMBANK IMPROVEMENTS - SHULLSBURG BRANCH
CITY OF SHULLSBURG, WI
 PROJECT LOCATION: SHULLSBURG BRANCH - EAST OF JUDGEMENT STREET
 OWNER: CITY OF SHULLSBURG; 190 N. JUDGEMENT ST., P.O. BOX 690; SHULLSBURG, WI 53586

REVISIONS:		
NO.	DATE	DESCRIPTION

AS-BUILT: _____ BY: _____

PRELIMINARY	
PROJECT NUMBER	D21-007
SHEET SCALE	SEE BAR SCALE
DRAWN BY	JORDAN FURE
DATE ISSUED	JUNE 6, 2022
SHEET DESC.	DESCRIPTION

SHEET TITLE:
C103
 SHEET NUMBER # 05 of 07

FOR QUESTIONS REGARDING THIS PROJECT, PLEASE CONTACT:

MR. JORDAN FURE, E.I.T.
 DELTA 3 ENGINEERING, INC.
 TELEPHONE: (608) 348-5355

CONSENT STATEMENT
 ALL RIGHTS RESERVED, AND NO REPRODUCTION WITHOUT CONSENT. ALL DRAWINGS, SPECS, REPORTS, DATA AND OTHER DOCUMENTS CONTAINED ON THIS PLAN SHEET ARE CREATED BY AND FOR DELTA 3 ENGINEERING AND THEIR CLIENTS' USE. REPRODUCTION OR DISTRIBUTION OF ANY CONTENT HEREIN, IN ANY FORM, WHETHER PRINTED, ELECTRONIC, OR OTHERWISE, REQUIRES THE EXPLICIT WRITTEN PERMISSION OF THE OWNER.

PROPOSED 2022 STREAMBANK IMPROVEMENTS -
SHULLSBURG BRANCH
CITY OF SHULLSBURG, WI
 PROJECT LOCATION: SHULLSBURG BRANCH - EAST OF JUDGEMENT STREET
 OWNER: CITY OF SHULLSBURG; 190 N. JUDGEMENT ST. - P. O. BOX 580; SHULLSBURG, WI 53586

PROPOSED 2022 STREAMBANK IMPROVEMENTS - SHULLSBURG BRANCH

EROSION CONTROL NOTES:

- GENERAL EROSION NOTES AND MAINTENANCE MEASURES ARE ILLUSTRATED ON THE PLAN SHEETS. AFTER AWARD OF THE CONTRACT, THE GENERAL CONTRACTOR SHALL INSTALL ALL BEST MANAGEMENT PRACTICES AS SHOWN ON THE PLAN SHEETS. ONCE INSTALLED, THE GENERAL CONTRACTOR SHALL CONTACT DELTA 3 ENGINEERING, INC. (608-348-5355). ONCE NOTIFIED DELTA 3 ENGINEERING INC. WILL VISIT THE SITE WITHIN 5 DAYS TO REVIEW THE SITE WITH THE GENERAL CONTRACTORS SUPERINTENDENT. UPON VISITING THE SITE, THE CONSULTING ENGINEER AND THE GENERAL CONTRACTORS SUPERINTENDENT WILL REVIEW THE SITE FOR COMPLIANCE WITH THE EROSION CONTROL MEASURES. IF AND WHEN ALL BEST MANAGEMENT PRACTICES REQUIRED TO COMMENCE SITE CONSTRUCTION ARE IN PLACE, THE CONSULTING ENGINEER AND PROJECT SUPERINTENDENT WILL SIGN AND CERTIFY THIS FACT. THIS REVIEW AND CERTIFICATION SHALL TAKE PLACE PRIOR TO THE REQUIRED PRE-CONSTRUCTION MEETING. THE SITE SUPERINTENDENT SHALL MAINTAIN AN AS-BUILT COPY OF THE EROSION CONTROL MEASURES ON SITE AT ALL TIMES. ANY ACTIVITIES INVOLVING INSTALLATION OF BEST MANAGEMENT PRACTICES SHALL BE INDICATED ON THE AS-BUILT PLAN WITH AN INSTALLED TIME AND DATE. RECORDED INFORMATION SHALL BE PERMANENTLY PLACED ON THE SITE MAP INCLUDING ANY CHANGES MADE TO THE BEST MANAGEMENT PRACTICES. IF THE SITE MAP BECOMES HARD TO READ, THE INITIAL DRAWING SHALL BE SAVED AND A CLEAN COPY SHALL BE ISSUED IN ORDER TO CONTINUE RECORDING ANY ON-SITE EROSION CONTROL ACTIVITY.
- A COMPLETE COPY OF ALL INSPECTION REPORTS, PLAN REVISIONS, ETC., MUST BE RETAINED AT THE PROJECT SITE AT ALL TIMES DURING DURATION OF THE PROJECT AND KEPT IN THE PERMANENT PROJECT RECORDS FOR AT LEAST FIVE YEARS FOLLOWING SUBMISSION OF THE NOTICE OF TERMINATION (NOT).
- THE GENERAL CONTRACTOR SHALL BE RESPONSIBLE FOR INSURING THAT ALL SUB-CONTRACTORS INVOLVED IN GROUND DISTURBING ACTIVITY COMPLY WITH THE EROSION CONTROL REQUIREMENTS.
- DAILY INSPECTIONS BY THE PROJECT SUPERINTENDENT AND MONTHLY INSPECTIONS BY THE OWNER'S CONSTRUCTION MANAGER MUST BE MADE TO DETERMINE THE EFFECTIVENESS OF THE EROSION CONTROL MEASURES. THE GENERAL CONTRACTOR IS TO INSPECT EROSION AND SEDIMENT CONTROLS WITHIN 24 HOURS AFTER A RAINFALL EVENT OF 0.5 INCHES OR GREATER. THE GENERAL CONTRACTOR SHALL BE RESPONSIBLE TO REPAIR OR REPLACE EROSION AND SEDIMENT CONTROL BEST MANAGEMENT PRACTICES AS NECESSARY WITHIN 24 HOURS OF INSPECTION.
- ONCE THE SITE REACHES FINAL STABILIZATION, ALL PERMANENT EROSION AND SEDIMENTATION CONTROLS ARE INSTALLED AND ALL TEMPORARY EROSION AND SEDIMENTATION CONTROLS ARE REMOVED, THE GENERAL CONTRACTOR AND OWNER MUST COMPLETE A FINAL SITE INSPECTION. UPON APPROVAL BY OWNER, THE OWNER AND GENERAL CONTRACTOR, AS APPLICABLE, MUST COMPLETE AND SUBMIT A NOTICE OF TERMINATION (NOT) FORM TO BE SUBMITTED TO THE WISCONSIN DEPARTMENT OF NATURAL RESOURCES.
- A RECORD OF THE DATES WHEN MAJOR GROUND-DISTURBING ACTIVITIES OCCUR, WHEN CONSTRUCTION ACTIVITIES TEMPORARILY OR PERMANENTLY CEASE ON A PORTION OF THE SITE, AND WHEN STABILIZATION MEASURES ARE INITIATED MUST BE MAINTAINED UNTIL THE NOT IS FILED. CONTROLS MUST BE IN PLACE DOWN GRADIENT OF GROUND-DISTURBING ACTIVITIES PRIOR TO THE COMMENCEMENT OF CONSTRUCTION.
- A LOG OF ALL INSPECTIONS BY FEDERAL, STATE, OR LOCAL STORM WATER OR OTHER ENVIRONMENTAL AGENCIES SHALL BE KEPT BY THE GENERAL CONTRACTOR. THE LOG SHALL INCLUDE THE DATE AND TIME OF VISIT AND WHETHER A REPORT WAS ISSUED OR WILL BE ISSUED AS A RESULT OF THE INSPECTION. ANY REPORTS ISSUED SHALL BE FAXED TO THE DELTA 3 ENGINEERING INC. 608-348-5455 (FAX).
- SOIL STABILIZATION - THE PURPOSE OF SOIL STABILIZATION IS TO PREVENT SOIL FROM LEAVING THE SITE. IN THE NATURAL CONDITION, SOIL IS STABILIZED BY NATIVE VEGETATION. THE PRIMARY TECHNIQUE TO BE USED AT THIS PROJECT FOR STABILIZING SITE SOIL WILL BE TO PROVIDE A PROTECTIVE COVER OF TURF GRASS OR PAVEMENT.
 - TEMPORARY SEEDING OR STABILIZATION - AREAS MAY BE STABILIZED TEMPORARILY WITH THE USE OF FAST-GERMINATING ANNUAL SEED, STRAW MULCH, WOOD CELLULOSE FIBERS, TACKIFIERS, NETTING OR BLANKET. WHERE CONDITIONS ARE FAVORABLE, AREAS SHALL BE TEMPORARILY STABILIZED WITHIN 7 DAYS AFTER CONSTRUCTION ACTIVITY CEASES. ALL DISTURBED GROUND WHERE THERE WILL NOT BE CONSTRUCTION FOR LONGER THAN 14 DAYS MUST BE SEEDING OR OTHERWISE STABILIZED.
 - PERMANENT SEEDING OR SOO - ALL AREAS AT FINAL GRADE MUST BE SEEDING OR SODDED WITHIN 3 DAYS AFTER COMPLETION OF THE MAJOR CONSTRUCTION ACTIVITY. EXCEPT FOR SMALL LEVEL SPOTS, SEEDING AREAS SHOULD GENERALLY BE PROTECTED WITH MULCH. ALL AREAS TO BE SEEDING WILL ALSO HAVE TOPSOIL AND OTHER AMENDMENTS AS STATED IN WISDOT SPECIFICATION SECTION 02800-PLANTING.
 - MULCHING - ALL AREAS THAT ARE TEMPORARY OR PERMANENT SEEDING SHALL BE MULCHED ACCORDING TO SECTION 627 - MULCHING OF THE WISDOT STANDARD SPECIFICATIONS FOR HIGHWAY CONSTRUCTION. ALL MULCH IS TO BE ANCHORED UTILIZING METHOD A, B, OR C.
 - EROSION CONTROL MATTING - FOR ANY SLOPES GREATER THAN 3:1, EROSION MATTING IS REQUIRED.
- STRUCTURAL CONTROLS - BEFORE ANY MAJOR GRADING ACTIVITIES, THE FOLLOWING BEST MANAGEMENT PRACTICES SHALL BE INSTALLED ON THE PROPOSED SITE - SILT FENCE, TEMPORARY TRACKING PAD, AND STORM SEWER INLET PROTECTION.
 - SILT FENCE - SILT FENCE IS A SYNTHETIC PERMEABLE WOVEN OR NON-WOVEN FABRIC TYPICALLY INCORPORATING WOODEN OR METAL SUPPORT STAKES AT INTERVALS SUFFICIENT TO SUPPORT THE FENCE, WATER, AND SEDIMENT RETAINED BY THE FENCE. SILT FENCE CAN ALSO BE INSTALLED WITH A WIRE FENCE BACKING. THE FENCE IS DESIGNED TO RETAIN SEDIMENT-LADEN WATER AND ALLOW SETTLEMENT OF SUSPENDED SOILS BEFORE THE STORM WATER FLOWS THROUGH THE FABRIC FOR DISCHARGE DOWNSTREAM. SILT FENCE SHALL BE LOCATED AS SHOWN ON THE PLAN SHEETS. THE SILT FENCE TO BE INCLUDED FOR THIS PROJECT SHALL BE CONSTRUCTED PER WISCONSIN DNR TECHNICAL STANDARDS FOR SILT FENCE (CODE 1656).
 - TEMPORARY TRACKING PAD - ALL ACCESS POINTS FROM THE PUBLIC STREET INTO THE CONSTRUCTION SITE SHALL INCLUDE A TRACKING PAD COMPOSED OF COURSE STONE TO THE DIMENSIONS SHOWN ON DETAIL SHEET (C201). ANY SEDIMENT REACHING A PUBLIC OR PRIVATE ROAD SHALL BE REMOVED BY STREET CLEANING (NOT FLUSHING) BEFORE THE END OF EACH WORKDAY.
 - STORM SEWER INLET PROTECTION - CURB AND GRATED INLETS ARE PROTECTED FROM THE INTRUSION OF SILT AND SEDIMENT THROUGH A VARIETY OF SEDIMENT CONTROL PRACTICES TO ALLOW SETTLEMENT OF SUSPENDED SOILS BEFORE DISCHARGING INTO THE STORM SEWER. GRATED INLETS TYPICALLY INCLUDE A STURDY FRAME WRAPPED IN GEOTEXTILE FABRIC OR SEDIMENT LOG PERIMETER TO SLOW THE FLOW OF WATER AND ALLOW PONDING WHERE SEDIMENT MAY SETTLE OUT. CURB INLETS TYPICALLY INCLUDE SEDIMENT LOG BARRIERS HELD IN PLACE WITH GEOTEXTILE FABRIC. OTHER MANUFACTURED PRODUCTS ARE ALSO AVAILABLE. ALL STORM DRAINS SHALL BE PROTECTED BY USING STRAW BALES, SEDIMENT LOGS, FABRIC, OR EQUIVALENT BARRIER. FINAL SITE STABILIZATION IS ACHIEVED WHEN TURF GRASS COVER PROVIDES PERMANENT STABILIZATION FOR AT LEAST 70 PERCENT OF THE DISTURBED SOIL SURFACE, EXCLUSIVE OF AREAS THAT HAVE BEEN PAVED.
- OTHER POLLUTANT CONTROLS
 - DUST CONTROL - CONSTRUCTION TRAFFIC MUST ENTER AND EXIT THE SITE AT THE STABILIZED CONSTRUCTION EXIT. THE PURPOSE IS TO TRAP DUST AND MUD THAT WOULD OTHERWISE BE CARRIED OFF-SITE BY CONSTRUCTION EQUIPMENT. WATER TRUCKS OR OTHER DUST CONTROL AGENTS WILL BE USED AS NEEDED DURING CONSTRUCTION TO REDUCE DUST GENERATED ON THE SITE. DUST CONTROL MUST BE PROVIDED BY THE GENERAL CONTRACTOR TO A DEGREE THAT IS ACCEPTABLE TO THE OWNER'S CONSTRUCTION MANAGER, AND IN COMPLIANCE WITH APPLICABLE LOCAL AND STATE DUST CONTROL REGULATIONS. AFTER CONSTRUCTION, THE SITE WILL BE STABILIZED (AS DESCRIBED ELSEWHERE), WHICH WILL REDUCE THE POTENTIAL FOR DUST GENERATION.
 - SOLID WASTE DISPOSAL - NO SOLID MATERIALS, INCLUDING BUILDING MATERIALS, ARE ALLOWED TO BE DISCHARGED FROM THE SITE WITH STORM WATER. ALL SOLID WASTE, INCLUDING DISPOSABLE MATERIALS INCIDENTAL TO THE MAJOR CONSTRUCTION ACTIVITIES, MUST BE COLLECTED AND PLACED IN CONTAINERS. THE CONTAINERS WILL BE EMPTIED AS NECESSARY BY A CONTRACT TRASH DISPOSAL SERVICE AND HAULED AWAY FROM THE SITE. THE LOCATION OF SOLID WASTE RECEPTACLES SHALL BE SHOWN AND APPROVED BY THE OWNER. SUBSTANCES THAT HAVE THE POTENTIAL FOR POLLUTING SURFACE AND/OR GROUNDWATER MUST BE CONTROLLED BY WHATEVER MEANS NECESSARY IN ORDER TO ENSURE THAT THEY DO NOT DISCHARGE FROM THE SITE. FOR EXAMPLE, SPECIAL CARE MUST BE EXERCISED DURING EQUIPMENT FUELING AND SERVICING OPERATIONS. IF A SPILL OCCURS, IT MUST BE CONTAINED AND DISPOSED SO THAT IT WILL NOT FLOW FROM THE SITE OR ENTER GROUNDWATER, EVEN IF THIS REQUIRES REMOVAL, TREATMENT, AND DISPOSAL OF SOIL. IN THIS REGARD, POTENTIALLY POLLUTING SUBSTANCES SHOULD BE HANDLED IN A MANNER CONSISTENT WITH THE IMPACT THEY REPRESENT.
 - SANITARY FACILITIES - ALL PERSONNEL INVOLVED WITH CONSTRUCTION ACTIVITIES MUST COMPLY WITH STATE AND LOCAL SANITARY OR SEPTIC SYSTEM REGULATIONS. TEMPORARY SANITARY FACILITIES MUST BE PROVIDED AT THE SITE THROUGHOUT THE CONSTRUCTION PHASE. THEY MUST BE SERVICED BY ALL CONSTRUCTION PERSONNEL AND MUST BE SERVICED BY A COMMERCIAL OPERATOR.
 - WATER SOURCE - NON-STORM WATER COMPONENTS OF SITE DISCHARGE MUST BE CLEAN WATER. WATER USED FOR CONSTRUCTION WHICH DISCHARGES FROM THE SITE MUST ORIGINATE FROM A PUBLIC WATER SUPPLIER, OR PRIVATE WELL APPROVED BY THE STATE HEALTH DEPARTMENT. WATER USED FOR CONSTRUCTION THAT DOES NOT ORIGINATE FROM AN APPROVED PUBLIC SUPPLY MUST NOT DISCHARGE FROM THE SITE. IT CAN BE RETAINED IN THE PONDS UNTIL IT INFILTRATES AND EVAPORATES.
 - CONCRETE WASTE FROM CONCRETE READY-MIX TRUCKS - DISCHARGE OF EXCESS OR WASTE CONCRETE AND/OR WASH WATER FROM CONCRETE TRUCKS WILL BE ALLOWED ON THE CONSTRUCTION SITE, BUT ONLY IN SPECIFICALLY DESIGNATED DIKED AREAS PREPARED TO PREVENT CONTACT BETWEEN THE CONCRETE AND/OR WASH WATER AND STORM WATER THAT WILL BE DISCHARGED FROM THE SITE. ALTERNATIVELY, WASTE CONCRETE CAN BE PLACED INTO FORMS TO MAKE RIP-RAP OR OTHER USEFUL CONCRETE PRODUCTS. THE CURED RESIDUE FROM THE CONCRETE WASHOUT DIKED AREAS SHALL BE DISPOSED IN ACCORDANCE WITH APPLICABLE STATE AND FEDERAL REGULATIONS. THE JOB SITE SUPERINTENDENT IS RESPONSIBLE FOR ASSURING THAT THESE PROCEDURES ARE FOLLOWED.
 - FUEL TANKS - TEMPORARY ON-SITE FUEL TANKS FOR CONSTRUCTION VEHICLES SHALL MEET ALL STATE AND FEDERAL REGULATIONS. TANKS SHALL HAVE APPROVED SPILL CONTAINMENT WITH THE CAPACITY REQUIRED BY THE APPLICABLE REGULATIONS. THE TANK SHALL BE IN SOUND CONDITION FREE OF RUST OR OTHER DAMAGE WHICH MIGHT COMPROMISE CONTAINMENT. HOSES, VALVES, FITTINGS, CAPS, FILLER NOZZLES, AND ASSOCIATED HARDWARE SHALL BE MAINTAINED IN PROPER WORKING CONDITION AT ALL TIMES.
- MINIMIZING EROSION AND RUNOFF DURING TRENCH OPERATIONS
 - EXCAVATED TRENCH MATERIALS SHALL BE PLACED ON THE UPPER SIDE OF THE TRENCH WHILE THE TRENCH IS OPEN.
 - EXCAVATED TRENCH MATERIAL, UPON COMPLETING WORK IN TRENCH, SHALL BE PLACED BACK IN THE TRENCH OR HAULED AWAY TO A PROPER SPOIL SITE. THE TRENCH SHALL BE BACKFILLED AND STABILIZED AT THE END OF EACH WORKING DAY.

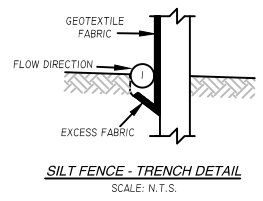
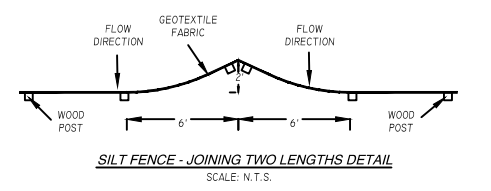

GENERAL NOTES- SILT FENCE:
 DETAILS OF CONSTRUCTION NOT SHOWN ON THIS DRAWING SHALL CONFORM TO THE PERTINENT REQUIREMENTS OF THE WISDOT STANDARD SPECIFICATIONS FOR HIGHWAY AND STRUCTURE CONSTRUCTION (MOST CURRENT EDITION) AND THE APPLICABLE SPECIAL PROVISIONS.

- TRENCH SHALL BE A MINIMUM OF 4' WIDE & 6" DEEP TO BURY AND ANCHOR THE GEOTEXTILE FABRIC. FOLD MATERIAL TO FIT TRENCH AND BACKFILL & COMPACT TRENCH WITH EXCAVATED SOIL.
- WOOD POST SHALL BE A MINIMUM SIZE OF 1-1/8" X 1-1/8" OF OAK OR HICKORY.

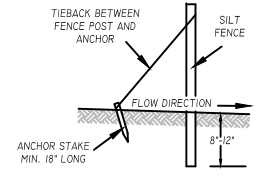
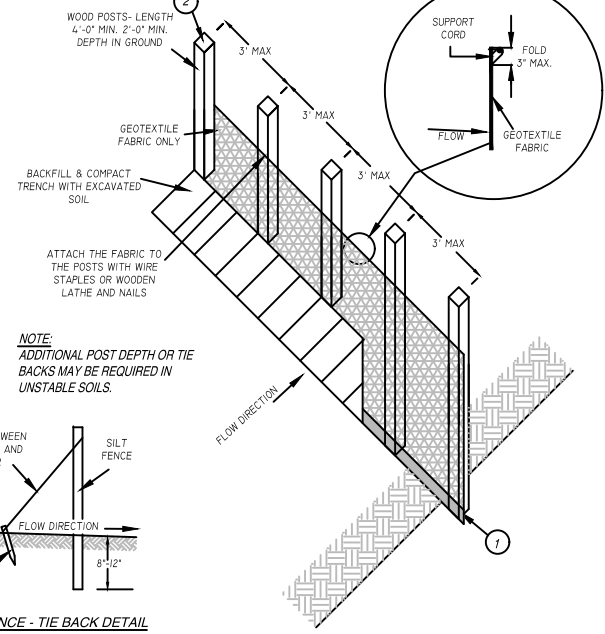

SILT FENCE DETAILS
SCALE: N.T.S.

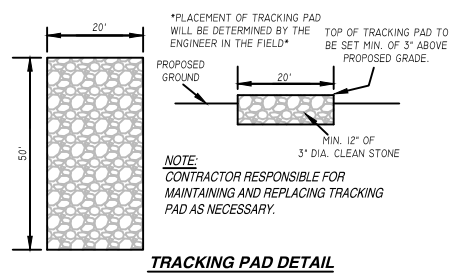

TRACKING PAD DETAIL
SCALE: N.T.S.

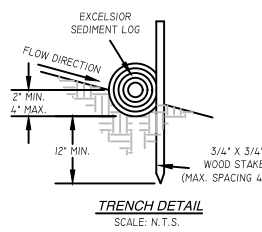

TRENCH DETAIL
SCALE: N.T.S.

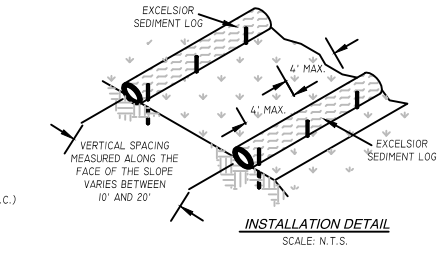

INSTALLATION DETAIL
SCALE: N.T.S.

TYPE 1 = 20\"/>

EROSION CONTROL SEDIMENT LOG
SCALE: N.T.S.

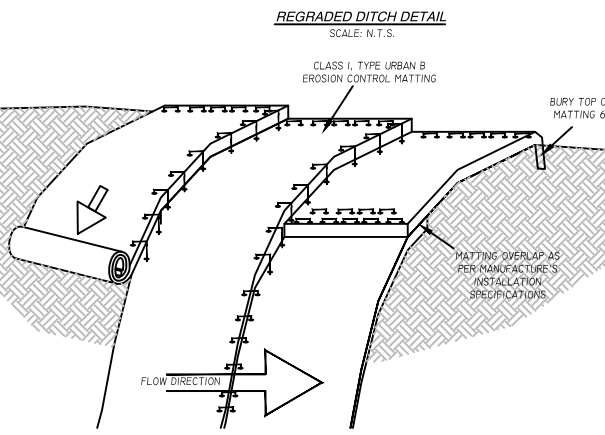

REGRADED DITCH DETAIL
SCALE: N.T.S.

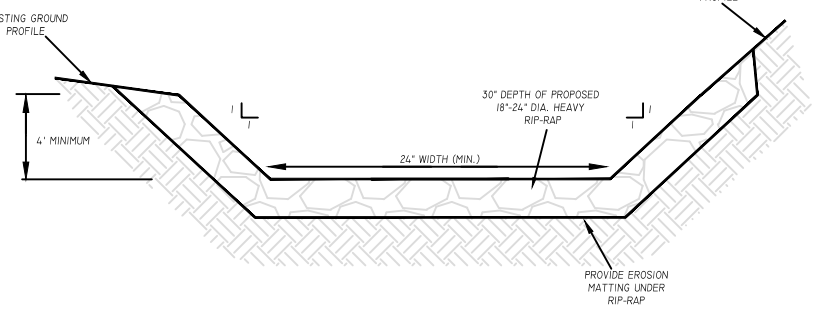

DRAINAGE DITCH DETAIL B-B
SCALE: N.T.S.

EROSION MATTING NOTES:

- PREPARE SOIL BEFORE INSTALLING BLANKETS, INCLUDING APPLICATION OF FERTILIZER AND MULCH AND SEED.
- BEGIN AT THE TOP OF THE SHOULDER (OR CHANNEL) BY ANCHORING THE BLANKET IN A 6\"/>

EROSION MATTING - SLOPE INSTALLATION DETAIL
SCALE: N.T.S.

Figure 1. Turbidity Barrier Placement Details

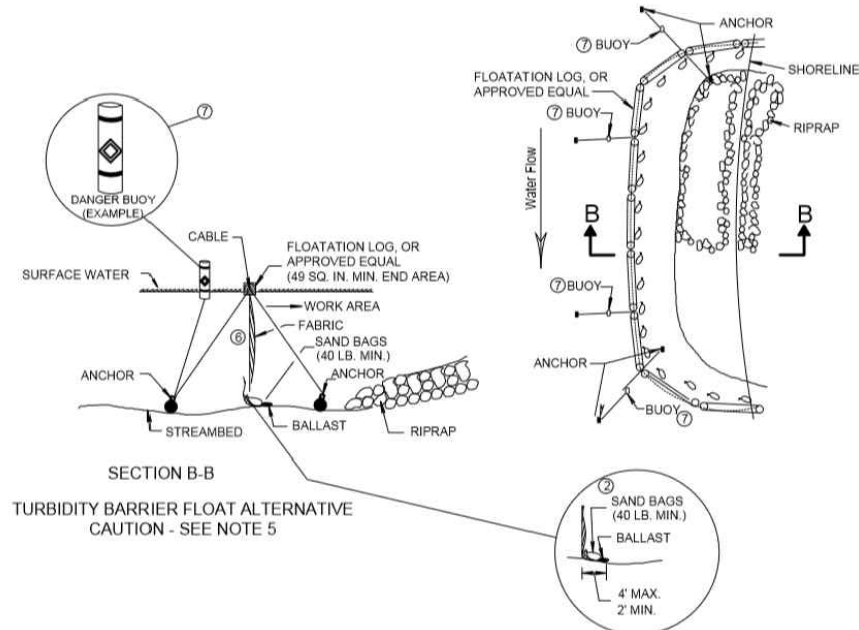

GENERAL NOTES

- DETAILS OF CONSTRUCTION, MATERIALS AND WORKMANSHIP NOT SHOWN ON THIS DRAWING SHALL CONFORM TO THE PERTINENT REQUIREMENTS OF THE STANDARD AND THE APPLICABLE SPECIAL PROVISIONS
- TURBIDITY BARRIER MAY BE REMOVED AT THE ENGINEERS OR PROJECT MANAGERS DISCRETION, WHEN PERMANENT EROSION CONTROL MEASURES HAVE BEEN ESTABLISHED.
- 1. DRIVEN STEEL POSTS, PIPES, OR CHANNELS. LENGTH SHALL BE SUFFICIENT TO SECURELY SUPPORT BARRIER AT HIGH WATER ELEVATIONS.
- 2. SANDBAGS TO BE USED AS ADDITIONAL BALLAST WHEN ORDERED BY THE ENGINEER OR PROJECT MANAGER TO MEET ADVERSE FIELD CONDITIONS. SPACE AS APPROPRIATE FOR SITE CONDITIONS.
- 3. WHEN BARRIER HEIGHT, H, EXCEEDS 8 FT., POST SPACING MAY NEED TO BE DECREASED.
- 4. IN WATERWAYS SUBJECT TO FLUCTUATING WATER ELEVATIONS, PROVISIONS SHOULD BE MADE TO ALLOW THE WATER TO EQUALIZE ON EACH SIDE OF THE BARRIER. THIS MAY BE ACCOMPLISHED BY LEAVING A PORTION OF THE BARRIER OPEN ON THE UPSTREAM END.
- 5. FLOAT ALTERNATIVE WILL ONLY BE ALLOWED WITH WRITTEN APPROVAL OF THE ENGINEER OR PROJECT MANAGER, AND IS MEANT FOR LOCATIONS WHERE BED ROCK PREVENTS THE INSTALLATION OF POSTS.
- 6. ALLOW SUFFICIENT SLACK VERTICALLY AND HORIZONTALLY SO THAT SEDIMENT BUILD UP WILL NOT SEPARATE OR LOWER THE TURBIDITY BARRIER.
- 7. USE AS DIRECTED BY COAST GUARD OR DNR PERMIT WHEN WORKING IN NAVIGABLE WATERWAYS.

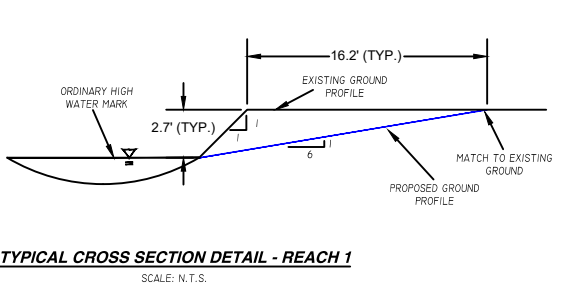
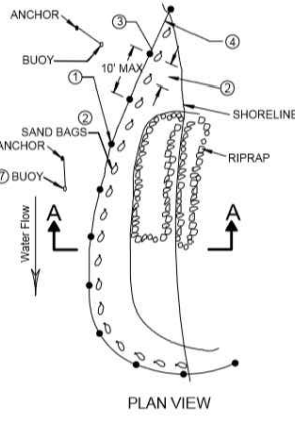
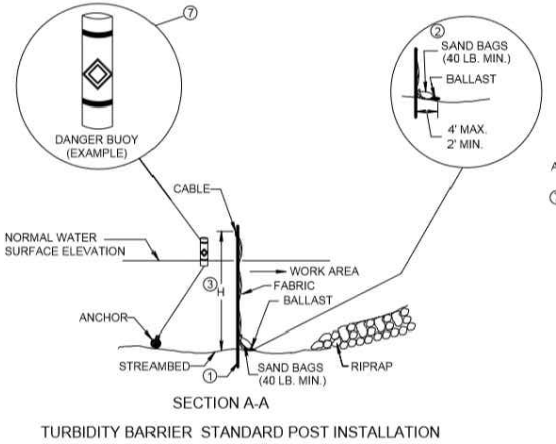

TYPICAL CROSS SECTION DETAIL - REACH 1

SCALE: N.T.S.

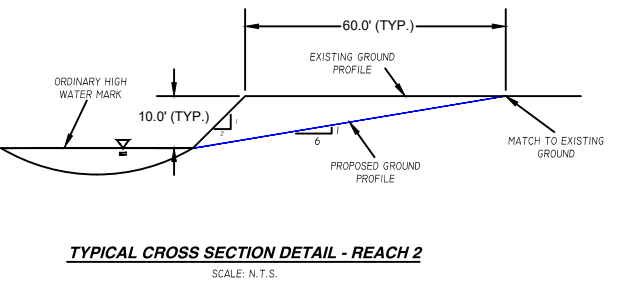

TYPICAL CROSS SECTION DETAIL - REACH 2

SCALE: N.T.S.

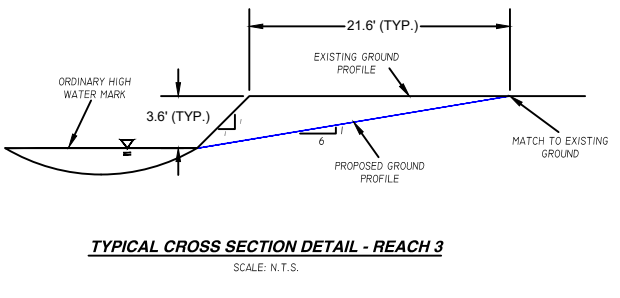

TYPICAL CROSS SECTION DETAIL - REACH 3

SCALE: N.T.S.

- NOTE:**
- 1. FENCE DETAIL (AS ILLUSTRATED) SHOWS ONE LEG OF FENCE CONSTRUCTION AT THE CORNER. THE CONTIGUOUS LEG TO BE IDENTICAL IN CONSTRUCTION.
 - 2. FENCE WIRE SHALL BE PROPERLY STRETCHED AND TIED.
 - 3. ALL SPLICED SECTIONS OF FENCE MUST BE TIED TO A FENCE POST.
 - 4. ALL BARBED WIRE STRANDS SHALL BE WRAPPED TWICE ROUND END POST AND STAPLED 4 TIMES(MIN).

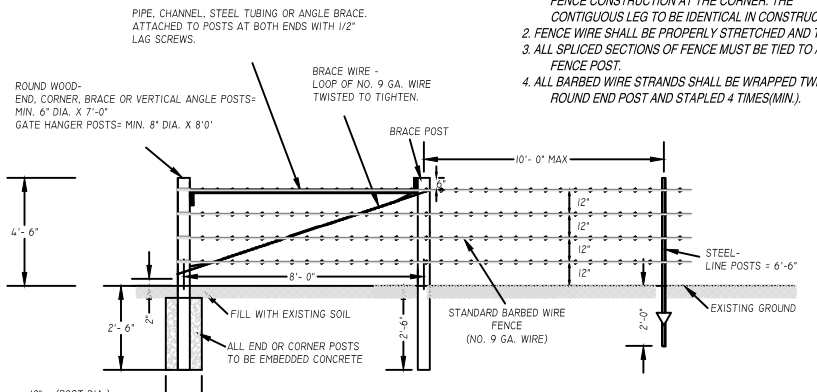

FENCE INSTALLATION DETAIL

SCALE: N.T.S.

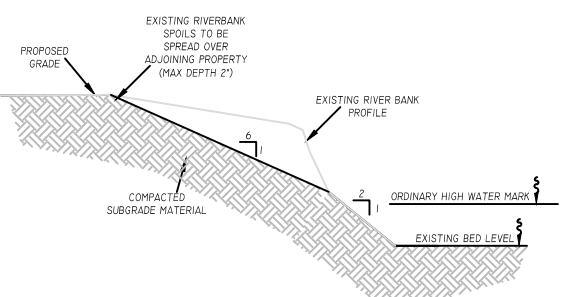

STREAM BANK GRADING (6:1 SLOPES) DETAIL

SCALE: N.T.S.

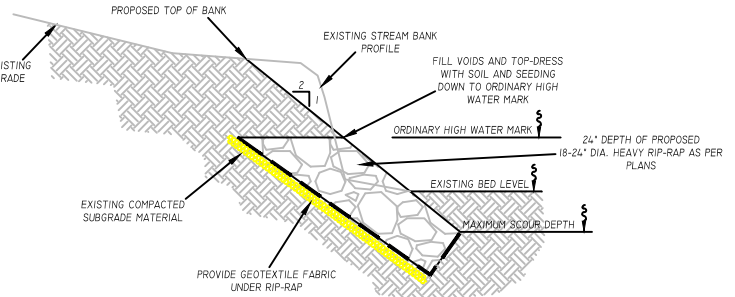

STREAM BANK GRADING (2:1 SLOPES) WITH RIP-RAP TO TOP OF BANK DETAIL

SCALE: N.T.S.

FOR QUESTIONS REGARDING THIS PROJECT, PLEASE CONTACT:
MR. JORDAN FURE, E.I.T.
 DELTA 3 ENGINEERING, INC.
 TELEPHONE: (608) 348-5355

CONSENT STATEMENT
 ALL RIGHTS RESERVED, AND NO REPRODUCTION WITHOUT CONSENT. ALL DRAWINGS, SPECS, REPORTS, DATA AND OTHER DOCUMENTS CONTAINED ON THIS PLAN SHEET ARE CREATED BY AND FOR DELTA 3 ENGINEERING AND THEIR CLIENTS USE. USE, REPRODUCTION, OR DISTRIBUTION OF ANY CONTENT HEREIN, IN ANY FORM, WHETHER PRINTED, ELECTRONIC, OR OTHERWISE, REQUIRES THE EXPLICIT WRITTEN PERMISSION OF THE OWNER.

PROPOSED 2022 STREAMBANK IMPROVEMENTS - SHULLSBURG BRANCH
CITY OF SHULLSBURG, WI
 PROJECT LOCATION: SHULLSBURG BRANCH - EAST OF JUDGEMENT STREET
 OWNER: CITY OF SHULLSBURG; 190 N. JUDGEMENT ST.; P.O. BOX 580; SHULLSBURG, WI 53586

REVISIONS		
NO.	DATE	DESCRIPTION

PRELIMINARY		
PROJECT NUMBER	D21-007	
SHEET SCALE	NOT TO SCALE	
DRAWN BY	C. COYIER	
DATE ISSUED	JUNE 6, 2022	
SHEET DESC.	DETAILS - EROSION CONTROL & NOTES	