

Revised Unit Cost Study

***For Commercial-Scale
Sediment Melter Facility***

Glass Furnace Technology

May 30, 2003

Prepared for:

***Wisconsin Department of
Natural Resources***



**UNIT COST STUDY
FOR COMMERCIAL-SCALE
SEDIMENT MELTER FACILITY**

1.0	INTRODUCTION.....	1
2.0	EXECUTIVE SUMMARY.....	2
3.0	PROCESS DESCRIPTION.....	3
3.1	Sediment preparation (pre-drying).....	3
3.2	Sediment drying.....	4
3.3	Dry sediment storage and dry sediment feed mixer.....	4
3.4	Melter feeding and operation.....	4
3.5	Melter quench tank.....	4
3.6	Melter off-gas treatment.....	5
3.7	Thermal oil energy supply and distribution system.....	5
3.8	Dryer exhaust gas treatment system.....	6
3.9	Circulating cooling water system.....	7
3.10	Air Separation Unit (ASU) oxygen supply.....	7
3.11	Dust control system.....	8
3.12	Plant wastewater summary.....	8
4.0	DESIGN DIFFERENCES FROM ORIGINAL UNIT COST REPORT.....	9
4.1	Lower Organic Content.....	9
4.2	Pre-Calcined Lime Flux.....	9
4.3	Higher Solids Content.....	9
4.4	Higher Glass Yield.....	10
4.5	Reduced Natural Gas Consumption.....	10
4.6	Reduced Oxygen Consumption.....	10
4.7	Higher Dryer Heat Transfer.....	10
4.8	Higher Wet Sediment Cohesion Point.....	11
4.9	Lower Installation Costs.....	11
4.10	Increased Natural Gas Price.....	11
5.0	COST ANALYSIS - BASE CASE.....	12
5.1	Projected Capital Cost.....	12
5.2	Projected Operating Costs.....	13
5.3	Present Value of 15-year Project.....	13
5.4	Summary of Assumptions.....	15
6.0	SENSITIVITY ANALYSES.....	17
6.1	Overview.....	17
6.2	Project Sizes.....	17
6.3	Sediment Storage.....	18
6.4	Stand-alone Facility Design.....	18
6.5	Project Life Sensitivity.....	18
6.6	Sediment Moisture Sensitivity.....	19
6.7	Sensitivity Tables.....	19

APPENDIX A - SENSITIVITY TABLES

APPENDIX B - DRAWINGS

1.0 INTRODUCTION

Minergy Corporation respectfully submits this report to the Wisconsin Department of Natural Resources (the “Department”) containing the results of a Revised Unit Cost Study for a commercial-scale sediment melter facility. The activities leading to this report are in conjunction with the Glass Aggregate Feasibility Study under the agreement between Minergy and the Department dated September 21, 2000, (State of Wisconsin purchase order number NMJ00001936), as amended under State of Wisconsin purchase order number NMB0000488 (the “Melter Demonstration Project”).

The Unit Costs derived in this report reflect additional data relative to capital and operating costs that was derived by Minergy as part of its Supplemental Testing work scope (State of Wisconsin purchase order number NMC00000118). The scope of that work included characterizing sediment behavior in large-scale dryers, mixers, conveyors, bins, agglomerators, and other material handling devices. To perform these sediment characterizations, Minergy secured samples of Fox River sediment from 6 locations along the river, including twelve 55-gallon drums from Deposit W1. Minergy’s sampling indicated different sediment characteristics than the sediment that was utilized in the Melter Demonstration Project. This report has factored in the sediment variances, which resulted in modified process flows, mass/energy balances, and resultant capital and operating costs.

This report is the result of a Cost Study and not an offer to construct a facility. The work performed within the scope of this study does not constitute detail engineering. Further detail engineering and design would improve the accuracy of the Cost Study results. Notwithstanding the Department’s or any other party’s desire to proceed with detail engineering or the development of a commercial scale facility, Minergy nonetheless reserves the right to make final determination on Minergy’s participation.

2.0 EXECUTIVE SUMMARY

This study represents an update of the unit cost study completed in January 2002. Input data was updated based on information derived from the concurrent study for sediment characterization. The base case estimates are made using a plant size of 250 glass tons per day. This size is consistent with that used elsewhere in the Glass Aggregate Feasibility Study.

Estimates were performed for initial capital cost (including installation), and annual operations and maintenance costs. The net present value (NPV) of these costs was calculated using the State-supplied discount factor of 5% over a 15-year project life. An NPV unit cost was calculated by dividing the NPV by the total number of tons of sediment processed over the life of the project.

The base case plant assumptions

Processing capacity.....	500 wet tons per day Sediment
Glass production.....	250 tons per day Glass
Operating timeframe	350 Operating Days/year
Staffing.....	25 Employees
Sediment solids content.....	55% solids

Base Case Cost results

Capital:	\$32 million
Annual operations & maintenance	\$6.2 million
15 Year NPV.....	\$97 million
Sediment processed.....	2.6 million tons
NPV Unit Cost.....	\$37 per wet ton of Sediment

Several sensitivities were included for various sized melter projects.

Cost Sensitivities Studied

Plant Capacity	4 project sizes
Sediment de-watering.....	6 levels of solids content from 30% - 55%
Operating days per year.....	Limited to dredging season or year-round
Project Life.....	7, 8, 10, 15 year lives

The resulting NPV unit cost range for all options was \$25 to \$55/ton. These results are consistent with the results derived in the original unit cost study.

3.0 PROCESS DESCRIPTION

This section describes the process and equipment used in the base project with a capacity of 250 glass tons per day. The facility is designed to process dewatered river sediment that has been dredged from the Fox River.

The sediment enters the plant, is mixed with previously dried sediment to make it easier to handle, and is then dried to approximately 5% moisture. (See Drawing FVRS-PF-101 – Process Flow Diagram, Sediment Drying and Preparation, and Drawing FVRS-GA-101 – Conceptual General Arrangement, Main Processing Plant, Appendix B.) After the sediment is mixed with a fluxing material, it is fed into a large melter, capable of maintaining temperatures of approximately 2600-2900 °F. The sediment melts into a molten material, which drains from the melter, is quenched in a water bath, and turns into a glass aggregate. The melter is designed to produce 250 tons per day of aggregate, which will be sold for building products.

The entire process is optimized to conserve energy, reduce heat losses, and minimize labor requirements.

3.1 Sediment preparation (pre-drying)

Sediment is dredged and mechanically dewatered by others at the site. The material is moved by front-end loader into the short-term storage/mixing area in the dryer plant. Three wet sediment mixers are installed in the dryer plant. (See Drawing FVRS-PF-101 – Process Flow Diagram, Sediment Drying and Preparation, Appendix B.) Sediment, which has already been dried (total moisture content of approximately 5%), is added to the inlet of the wet sediment mixer. The purpose for the mixing is to improve material handling and behavior in the dryers, by eliminating self-agglomeration (otherwise known as cohesion point or “sticky phase”) of the material. The moisture content of the sediment after mixing is approximately 25%.

3.2 Sediment drying

After the sediment has been prepared by mixing, it is transported by enclosed conveyors to the dryer. The heat source for the dryers will be high temperature thermal oil, which in turn has been heated by the energy recovery system on the backend of the sediment melter. The sediment moisture content is reduced in the dryers from 25% to 5%. Water vapor from the drying of the sediment is exhausted to a vapor collection system, as described in *Dryer exhaust gas treatment system*, section 3.8.

3.3 Dry sediment storage and dry sediment feed mixer

Each drying line will have a dry sediment silo for storage of material to allow flexibility of operations. The dry sediment storage hopper discharges sediment to a small surge hopper at the wet sediment mixers or to a dry sediment mixer. A lime silo provides a supply of ground limestone to the feed mixer to work as a fluxing agent for control of the melting temperature. The dry sediment mixer combines the dry sediment with the lime. A conveyor will transport the material discharged from the dry sediment mixer to the melter inlet surge hopper.

3.4 Melter feeding and operation

A total of six chargers supply the melter with dry and fluxed river sediment. The melter heats the sediment to 2600 °F to 2900 °F. The molten material exits the main melter section and enters the forehearth. The forehearth then drains the hot glass into a water-filled quench tank. The glass furnace is heated with oxy-fuel fired burners. The burners are supplied by oxygen/natural gas control system fuel rails. Oxygen is provided by an on-site oxygen generation plant. Hot exhaust gas generated by the melter is exhausted into a hot gas heat recovery system and air quality control equipment (AQCE) prior to the exhaust stack.

3.5 Melter quench tank

The quench tank is water-filled, and receives the hot glass flow from the melter. The direct contact of the hot glass with the water will cause the material to solidify and fracture into the glass aggregate product. A screw or paddle conveyor is used to remove glass aggregate from the bottom of the quench tank. The conveyor is inclined in an enclosure, and as the aggregate is removed up the incline, free water drains back into the quench tank. The conveyor discharges

the aggregate to an adjacent storage pile. The quench tank will be in a closed cooling water loop. The quench tank temperature will be maintained by constant circulation of water through a set of heat exchangers.

3.6 Melter off-gas treatment

The exhaust gas from the melter exits at 2700 to 2850 °F into the exhaust flue. (See Drawing FVRS-PF-102 – Process Flow Diagram, Melter Exhaust Heat Recovery and AQCE, Appendix B.) The exhaust flue also receives cool exhaust gas from an exhaust gas recirculation fan, which blends the cooler and hotter gases together within the flue. The cooled flue gas enters a heat recovery/thermal oil (HRTO) unit. The HRTO heats thermal oil, which is used to supply energy to the sediment drying process.

The flue gas exiting the HRTO is split into two parts. The first part is used as flue gas recirculation, and is routed back through a flue gas recirculation fan (FGR) into the blending section of the melter exhaust gas flue. The second part of the flue gas flow enters a high-energy venturi and packed tower section. The venturi section removes particulate from the exhaust, and the packed tower section removes SO₂. A packed tower is a device used to remove soluble gases by spraying water (along with treatment chemicals) through the gas stream. The water in the packed tower is in a closed recirculation loop. The packed tower operates in the condensing mode, requiring some blowdown water (ie, a slip stream) from the loop. Sodium hydroxide is the treatment chemical added to the packed tower water loop to control pH and provide for optimum SO₂ removal.

After the exhaust gas exits the packed tower, the flue gas enters a fabric filter. This device provides additional control and is especially effective for fine particulate. The exhaust flow from the fabric filter proceeds to a carbon filter bed. The carbon filter bed provides for removal of mercury, and can also remove other chlorinated organic compounds. After the exhaust gas exits the carbon bed, the gas is exhausted through the stack.

3.7 Thermal oil energy supply and distribution system

The main purpose of the thermal oil system is to provide thermal energy to the sediment dryers for the drying process. (See Drawing FVRS-PF-104 – Process Flow Diagram, Thermal Oil Supply System, Appendix B.) The system consists of the following components:

- (1) A thermal oil auxiliary heater, which uses natural gas to heat thermal oil. The amount of natural gas fired in the unit is a function of the dryer plant energy demand. The amount of gas firing is controlled by monitoring thermal oil temperature, in inverse proportions.
- (2) The HRTO unit, which recovers energy from the melter hot exhaust gas.
- (3) An auxiliary heat sink (AHS), which dissipates heat in the event that one or all of the sediment dryers are not operational, while the HRTO continues to recover heat from an operational melter. The AHS unit is a standard shell and tube heat exchanger. Heat will be dissipated to the circulation water system.
- (4) Circulation pumps and control valves, which provide the necessary energy to force the circulation of the thermal oil at the required process conditions.
- (5) A thermal oil expansion tank.
- (6) A thermal oil drain tank. Both items (5) and (6) are standard features for thermal oil systems, and are necessary for proper operation and maintenance of the system.

3.8 Dryer exhaust gas treatment system

The process of sediment drying forces water that is contained in the wet sediment feed to vaporize, while the sediment is in contact with the heated components of the sediment dryer. To assist in efficient removal of the water vapor, a controlled volume of sweep air is admitted into the dryer housing. (See Drawing FVRS-PF-103 – Process Flow Diagram, Dryer Off Gas Treatment, Appendix B.) At the opposite end of the dryer housing, the combined water vapor and sweep air are exhausted from the dryer unit. The exhaust gas passes through a mechanical collector. The mechanical collector removes a large percentage of the sediment dust that is entrained in the water vapor/sweep air mixture that is exhausted from the dryer. The dust is collected and the material is recombined with the dry sediment in any one of the dry sediment storage silos.

To provide for a “zero emissions” design, the water vapor/sweep air mixture is introduced into a venturi scrubber and packed tower arrangement. This device is similar in function to the venturi collector and packed tower used on the melter exhaust gas treatment system. The venturi collector removes an additional fraction of entrained sediment dust from the dryer exhaust stream. The water vapor is then condensed and removed by the packed tower section of the unit. A steady stream of water is circulated from a closed cooling water loop to the top of the packed

tower. The condensing process increases the water volume in the cooling loop, requiring some blowdown of water to a wastewater treatment facility.

The exhaust gas that exits the packed tower section is circulated by an exhaust fan. The entire dryer and exhaust system operates under a negative pressure condition to prevent fugitive dust emissions from the dryer casings. Since some inward air leakage is expected, a small vent stream will be split off from the exhaust fan. The exhaust stream will be directed to one of the burners on the melter. This will provide destruction of any organics in the dryer exhaust. The balance of the exhaust fan discharge is directed back to the sediment dryers as the sweep air source.

3.9 Circulating cooling water system

A number of systems will require a steady stream of cooling water to remove heat. All of the systems use non-contact heat exchangers to prevent contamination of the cooling water system. The cooling system is a closed system. Heat is dissipated through a mechanical draft cooling tower. Make-up water is required to recover some evaporative losses from the system. Blowdown water will need to be drained from the cooling tower to limit total dissolved solids (TDS) concentrations in the water.

Circulating water is pumped to the users by motor-driven centrifugal pumps. The major users of circulation water are:

- (1) Indirect heat exchanger for exhaust gas packed tower cooling system.
- (2) Indirect heat exchanger for dryer exhaust gas packed tower cooling system.
- (3) Aggregate quench tank indirect cooling heat exchanger.
- (4) Cooling water for the thermal oil auxiliary heat dissipation unit.
- (5) Charger cooling water.
- (6) Cooling water required for the oxygen generation system.

3.10 Air Separation Unit (ASU) oxygen supply

Oxygen will be generated on-site. The approximate oxygen volume needed will require the generation of 95 tons of oxygen per day. The plant will be completely designed and constructed from the foundations up by a third party using their standard designs, so no detailed process description is included in this document. The sediment drying and melting facility will need to

interconnect utilities and infrastructure to the oxygen plant to minimize infrastructure development costs. The main requirement will be the supply of 4160V power from the dryer and melting facility electric substation to the ASU.

3.11 Dust control system

All of the sediment conveyors, storage hoppers and silos will have a closed design. To prevent fugitive emissions from the conveyor systems, they will be ventilated continuously. The exhaust will be directed to a high efficiency fabric filter. All collected dust will be directed back to one of the dry sediment storage silos.

3.12 Plant wastewater summary

There are three sources of process wastewater for the operation.

- 1) The condensate from the dryer exhaust results in a waste stream of 34 GPM. This waste stream has a wastewater loading estimated to be 1000 to 3000 ppm of total suspended solids (TSS). The suspended solids will consist of sediment particles that are carried out of the dryers. There is a potential that PCBs are attached to the sediment particles, requiring this flow stream to be treated by the same wastewater treatment facility processing the dredged sediment.
- 2) The packed tower on the exhaust of the melter generates 8 GPM of blowdown. This flow stream will have TSS and chemical oxygen demand (COD), and will need to be sent for additional wastewater treatment. The discharge volume and concentration levels should not require any pretreatment prior to discharge to the publicly owned treatment works (POTW).
- 3) The cooling tower generates a maximum blowdown flow of 10-30 GPM, depending on outside air temperature and humidity. This flow can be permitted as a non-contact cooling water source. If the proper permits are obtained, it is possible to either discharge the water into the stormwater sewer system or into the final effluent of the wastewater treatment facility for the dredge water.

4.0 DESIGN DIFFERENCES FROM ORIGINAL UNIT COST REPORT

The original Unit Cost Report used as its basis the sediment that was provided from the SMU 56-57 demonstration dredging project. Small variations were observed from sediment secured for this Scope of Work. These factors have been incorporated into this revised Unit Cost Report in an effort to refine and substantiate the results.

4.1 Lower Organic Content

Sediment has very low fuel value and therefore does not burn autogenously. However, in a large melter the organic matter contained in the sediment does account for a portion of the heat input to the process. The mass/energy balances and the design must incorporate this heat input. During the original Unit Cost Study, the sediment's Gross Calorific Value (GCV) was 1300 btu/lb. During Minergy's Supplemental Testing, a lower GCV was seen in the samples of Fox River sediment secured for that work. The end result is a lower contribution of heat input from sediment, with the balance being made up from natural gas. As seen in section 4.5, however, overall natural gas consumption decreased due to other factors outweighing this increase.

4.2 Pre-Calcined Lime Flux

To optimize melting temperatures, Minergy has specified changes in the lime fluxing additions. The original sediment from 56-57 had lime added at the de-watering station; therefore, no additional lime was necessary. The first Unit Cost Study assumed the addition of calcium carbonate would suffice for the flux addition, but since the lime had already been added, no study of the alternatives was possible. Work associated with this scope concluded that the process can be optimized from the perspective of melting temperature and energy efficiency by using a pre-calcined lime flux. Pre-calcined lime flux is more effective (but more expensive), than calcium carbonate. The calcining process at the lime supplier's facility removes carbonates. In comparison, using calcium carbonate (ie, non-pre-calcined lime) in the melter would require additional natural gas and oxygen to remove the carbonates.

4.3 Higher Solids Content

The SMU56-57 demonstration project used plate and frame presses which achieved 50% solids. At the instructions of the Department and with supporting data from belt press manufacturers, the base case solids content was increased from 50% to 55%. This is attributable to equipment

that the Department has been able to specify which reduces water content in cake solids more effectively. Because less water is delivered to the melter plant, less energy is required to evaporate it, and less natural gas is used. This change also modifies the number of total tons processed by the facility, due to less water in the deliveries.

4.4 Higher Glass Yield

Glass Yield is the ratio of glass output per dry-basis sediment feed. The Lower Organic Content and Pre-Calcined Lime Flux has the net effect of increasing glass yield. To keep comparisons between the versions of the Unit Cost Study as even as possible, it was decided to maintain the design-basis of 250 tons per day of glass production, and vary the sediment feed rate correspondingly. The Original Unit Cost's base-case 250 ton/day unit processed 600 wet tons per day (at 50% solids); this version processes 500 wet tons per day (at 55% solids).

4.5 Reduced Natural Gas Consumption

Higher Glass Yield and the use of Pre-Calcined Lime Flux reduce the amount of natural gas required in the process.

4.6 Reduced Oxygen Consumption

The Lower Organic Content, Higher Glass Yield, Reduced Natural Gas Consumption, and the use of Pre-Calcined Lime Flux, decreases the amount of oxygen required.

4.7 Higher Dryer Heat Transfer

During the dryer demonstration portion of the Phase 3 EPA SITE testing program, Fox River sediment was dried at the Hazen Research Laboratory in Golden, CO, in a small Holo-Flite indirect disc dryer. The primary purpose of the testing was to monitor PCB fate during the drying process. Information regarding the dryer's heat transfer and energy consumption was gathered; however, this information is of limited usefulness because the flights of the dryer were not kept full and the unit was not operated in a manner to optimize heat transfer. The original version of the Unit Cost Study used the low heat transfer number obtained during this test as a conservative assumption. Supplemental testing by three separate dryer manufacturers in large scale pilot dryers (performed as part of this work scope) has yielded higher heat transfer rates. Equipment suppliers used these new values in specifying equipment for this version of the Study, which

resulted in lower operating and capital costs. The same number of dryers was included (3 dryers for each 250 glass ton/day line), but each was smaller due to better heat transfer.

4.8 Higher Wet Sediment Cohesion Point

During the first Unit Cost report, it was assumed that sediment that had been dried to greater than 61% solids would not exhibit cohesion. This was based on the results of testing as Hazen Research on sediment that was provided from the SMU56-57 project. As indicated above, that sediment had been limed prior to introduction to the dewatering presses. The lime addition may have skewed the Hazen cohesion test. Minergy provided sediment samples obtained during this Work Scope to three different dryer companies (this sediment was not pre-limed). Each reported a cohesion point of approximately 75%. The end results of this information does not change the design or operation of the full scale facility over the assumptions used in the original Unit Cost study. This section has been included in this report to provide feedback on a possibility that had been considered attractive from a design perspective: assuming the old target of 61%, that a mechanical dewatering press could press sediment above the cohesion point, thus eliminating the need for a dryer backmixing circuit. The newly discovered cohesion point of 75% is above the technically feasible pressing capability of mechanical presses. Therefore, the original assumption of a dryer backmix circuit has been retained in this version of the Unit Cost Study.

4.9 Lower Installation Costs

Installation costs were reduced by receiving feedback from construction contractors. Contractors specializing in mechanical, electrical, and building installations reviewed the facility design. The net costs were reduced for installation accordingly.

4.10 Increased Natural Gas Price

Since the release of the first Unit Cost Report, prices in the U. S. Government's long-term natural gas forecast have increased; however, the increase is not of the same magnitude as that which has been experienced in the winter of 2002-03. Factoring in the likely in-service timeframe of a full scale facility, and using delivered prices for industrial users, the forecasts are calling for an average price of \$3.55 per million btu. This is approximately 10% higher than was used in the first Unit Cost Report.

5.0 COST ANALYSIS - BASE CASE

Using the indicated assumptions and design basis changes, new assumptions and resultant costs were estimated. These results are for a single-unit, 250 glass ton per day melter, which is consistent with the Original Unit Cost Study.

5.1 Projected Capital Cost

Item	Cost
Melter (delivered and installed)	\$ 7,034,667
Dryer (total for 3, equipment only)	\$ 2,819,336
Material handling system	\$ 1,852,209
Dryer off gas system equipment	\$ 370,069
Thermal oil system equipment	\$ 932,320
AQCE system equipment	\$ 432,671
Balance of Plant equipment	\$ 455,749
Controls & Instrumentation	\$ 518,871
Mechanical contractor	\$ 4,150,762
Electrical contractor	\$ 1,753,955
Footings and foundation contractor	\$ 535,004
Start-up costs	\$ 714,779
Main building	\$ 2,467,541
Engineering	\$ 5,263,233
Sediment Storage Building	\$ 3,000,000
TOTAL:	\$ 32,301,166
Total from Original Unit Cost Report	\$ 36,768,000
Difference:	-12%

5.2 Projected Operating Costs

Item	Annual Cost
Gas	\$1,159,998
Electricity	\$ 797,942
Labor	\$1,625,000
Supplies	\$1,247,918
Lime Flux	\$ 923,392
General & Administrative	\$ 455,557
TOTAL:	\$6,209,808
Total from Original Unit Cost Report	\$6,844,045
Difference	-9%

5.3 Present Value of 15-year Project

Minergy calculated the Present Value of the capital and operating costs of the project. It was assumed that, similar to most industrial facilities, the equipment would be operating for a 15-year duration. The Present Value of the costs was calculated to be \$108 million. In comparison to the Present Value calculated in the original Unit Cost Report (\$97 million) this represents a change of -10%. In spite of the overall net decreases in Capital, Operating, and Present Value, the Unit Cost is slightly higher in this version. This is attributable to the higher solids content and higher glass yield (discussed in sections 4.3 and 4.4 of this report). Higher solids content reduces the amount of water received at the facility, but also reduces the number of wet tons over which costs are spread. Higher glass yield reduces the amount of sediment to be processed in a Glass Furnace of fixed glass production.

The Department has expressed some concern that 15 years may be longer than is currently proposed for the Fox River cleanup. For a base case comparison against the Original Unit Cost report, we have maintained the 15 year life. To address the life-of-project concerns, we have included an extensive set of sensitivities in Section 5.0 of this report. These sensitivities calculate the unit costs of operating a variety of different size facilities for varying lengths of

time. These options should be helpful in finding a project size and duration that accommodates the outcome of the final remedial design.

Estimated Present Value 250 Glass Ton per Day Sediment Melting Plant

Assumptions:		
Project life =		15 years
Interest rate =		5.0%
Days per Year =		350
Sediment processing rate =		500 tons daily
Total sediment processed =		2,625,000 tons over project life
Construction costs =	\$32,300,000	
Operating costs =	\$6,209,808 annually	
Income from glass sales =	\$2 - \$25 per ton of glass sold	
Glass production rate =	250 tons daily	
Estimated Costs:		
	Initial Costs	Net Annual Costs
Construction costs	\$32,300,000	
Operating costs with no glass sales		\$6,209,808
Operating costs minus glass income at \$2/ton		\$6,034,808
Operating costs minus glass income at \$25/ton		\$4,022,308
Total Present Worth Cost of Project:		
No glass sales	\$96,755,682	
With glass sales at \$2/ton	\$94,939,242	
With glass sales at \$25/ton	\$74,050,180	
Unit Costs (Per Ton of Sediment Processed):		
No glass sales	\$36.86	
With glass sales at \$2/ton	\$36.17	
With glass sales at \$25/ton	\$28.21	

5.4 Summary of Assumptions

Several assumptions were made for the Base Case of this Cost Study.

1. The following assumptions were made relative to incoming sediment:
 - a. Previously de-watered to 55% solids
 - b. Previous removal of all debris, including metal and other material greater than ¼-inch in size
 - c. Received in a non-frozen state, even during winter operations
 - d. Gross calorific value (GCV) of approximately 800 Btu per pound
 - e. Loss on ignition of approximately 17%
 - f. Fluxing requirement of 15% lime
 - g. Cohesion does not occur above 75% solids

2. The following assumptions were made relative to facility permitting:
 - a. Facility will be permitted under CERCLA site exemption and meets ARARs identified in Minergy's Permitting Feasibility Study
 - b. Oxyfuel is best available control technology (BACT) for NO_x control
 - c. Wet scrubber at 95% control is BACT for SO₂

3. The following assumptions were made relative to the facility design:
 - a. Facility is staffed for 24 hours per day, year-round
 - b. Site soils are capable of loading to 2500 pounds per square foot
 - c. No provisions have been incorporated for soil testing or boring
 - d. No compactor is assumed necessary for feeding to the melter
 - e. The dryers require 30 Btu per square foot per degree F
 - f. Dryer maximum throughput is 600 tons/day (on the basis of 50% solids)
 - g. Facility design will be for an industrial area
 - h. No underground utility relocation is required
 - i. No pre-construction site remediation is required

4. The following assumptions were made relative to the cost of supplies:
 - a. The gas price was assumed to be \$3.55 per million Btu
 - b. The electricity price was assumed to be 4½ cents per kilowatt hour
 - c. The lime flux cost was assumed to be \$62.00 per ton
 - d. The oxygen cost is assumed to be 6 cents per hundred cubic feet from a 3rd party

5. No provisions were included for the following items:
 - a. Salvage/removal at the end of the plant's economic life
 - b. Dredging, dewatering, and delivery of cake solids
 - c. Hedges or other financial instruments on commodity prices
 - d. Site development costs other than those explicitly listed
 - e. Financing costs during and after plant construction and working capital requirements

6.0 SENSITIVITY ANALYSES

6.1 Overview

A series of sensitivity analyses have been performed on the base project. These analyses estimate the capital, operations and maintenance (O&M), and unit cost of melter projects of varying sizes. These costs were derived using a combination of build-up estimates, generally accepted scale factors, and operational experience. The base case project was used as a reference.

Each major capital line item was analyzed to determine the new expected values, factoring in the impacts of the larger or smaller sized plants. For example, the slope of the cost curve of a melter is rather flat because a large portion of the cost of a melter is fixed. Sediment dryer plants, in comparison, scale fairly well due to the use of multiple dryer lines for each facility (increasing or decreasing the capacity of the plant is done by using more or fewer dryer lines).

The O&M line items were also analyzed individually to determine the new expected values. These items fall into two categories: fixed and variable O&M. Variable O&M items include natural gas, oxygen, electricity, and lime flux, the consumption of which varies in proportion to the amount of processing. Fixed O&M included staffing, G&A, and maintenance, although these items were individually estimated for each plant size.

6.2 Project Sizes

The project sizes were varied as indicated:

- A. 1 x 250: This is the base case project described in this report. This facility has one sediment melter rated at 250 glass tons per day and two or three dryers rated at 200 to 300 tons each (at 50% solids), along with the associated balance of plant.
- B. 2 x 250: This facility has two sediment melters each rated at 250 glass tons per day and four to six dryers rated at 200 to 300 tons each (at 50% solids), along with the associated balance of plant.
- C. 2 x 375: This facility has two sediment melters each rated at 375 glass tons per day and six dryers rated at 300 tons per day each (at 50% solids), along with the associated balance of plant.

- D. 3 x 375: This facility has three sediment melters each rated at 375 glass tons per day and nine dryers rated at 300 tons per day each (at 50% solids), along with the associated balance of plant.

6.3 Sediment Storage

The sensitivity analysis included provisions for each project to operate at 240 or 350 days per year. Limiting operations to 240 days per year would coincide with the 8-month dredging season, and avoid the capital expenditure of a building to store sediment and minimize potential permitting problems with storing such material and reduce footprint. To operate 350 days per year, a storage would be used into which one-third of the de-watered sediments would be placed during the dredging season. During the non-dredging season, the accumulated inventory would be used as feedstock to the melter plant. For each 250 glass ton per day increment of capacity, sufficient storage could be accomplished using a 60,000 square foot building. The estimated cost of such a building would be \$3 million per 250 glass ton/day unit.

6.4 Stand-alone Facility Design

All of the melter projects have been designed to be stand-alone facilities. However, it is possible, and potentially desirable, to integrate the operation of any of these facilities into that of an adjacent industrial facility with which it can share operational resources. Integration tends to be more applicable to the smaller projects. Operational savings of approximately \$500,000 per year could be achieved through integration. However, for the purposes of clarity, this sensitivity study assumes each of the facilities is a stand-alone entity.

6.5 Project Life Sensitivity

Analyses were performed on each of the above listed project sizes, with and without sediment storage, for 7, 8, 10, and 15 year fixed project lives. It was assumed that at the end of the project life that the facility would be closed and no longer used for this purpose. No credit was applied toward scrap, removal, or facility re-use, as these would be speculative at this time.

Analyses were also performed on each of the above listed project sizes, with and without sediment storage, for a number of target project scopes. This analysis assumed that each of the projects would be operated with a target of a certain number of tons of dredged material to

process. When the target is reached, it was assumed that the facility was closed. No credit was applied toward scrap, removal or facility re-use, as these would be speculative at this time.

Project sizes were:

- 1,500,000 Dry tons (equivalent to 2,720,000 wet tons at 55% solids)
- 1,980,000 Dry tons (equivalent to 3,600,000 wet tons at 55% solids)
- 2,420,000 Dry tons (equivalent to 4,400,000 wet tons at 55% solids)
- 3,575,000 Dry tons (equivalent to 6,500,000 wet tons at 55% solids)

6.6 Sediment Moisture Sensitivity

The dryers that have been included in this cost study have substantial evaporative capacity above that which would be required for cake solids described in the base case (that is, 55% solids).

This means the facility could accommodate wetter sediment and not have the capacity limited by dryer throughput. Each of the above listed scenarios, with and without storage, for varying project lives and varying amounts of target sediment processing, was studied at varying sediment solids content, as follows:

- 55% wet sediment solids content
- 50% wet sediment solids content
- 45% wet sediment solids content
- 40% wet sediment solids content
- 35% wet sediment solids content
- 30% wet sediment solids content

6.7 Sensitivity Tables

Tables containing the results of all the sensitivity cases are included in Appendix A.

Appendix A - Sensitivity Tables

UNIT COST ESTIMATES
PROJECTS IN SERVICE FOR FIXED AMOUNT OF TIME

SEDIMENT FEED 55% SOLIDS

Plant Size, Glass tons/day	1 x 250		2 x 250		2 x 375		3 x 375	
Daily capacity (tons)	500		1,000		1,500		2,250	
Storage Building Size (tons)	n/a	55,000	n/a	110,000	n/a	165,000	n/a	247,500
Days/yr Operation	240	350	240	350	240	350	240	350

15 Year Project Life	Project Life (years)	15	15	15	15	15	15	15	15
	Sediment Processed (million wet tons)	1.8	2.6	3.6	5.3	5.4	7.9	8.1	11.8
	Capital (\$million)	29.30	32.30	56.23	62.23	70.39	79.39	102.03	115.53
	Annual O&M (\$million)	4.83	6.21	8.42	11.18	11.43	15.57	16.55	22.76
	NPV before Glass Sales (\$million)	79.44	96.76	143.65	178.30	189.06	241.02	273.80	351.74
	Unit Cost (\$2 Glass)	\$ 43.44	\$ 36.17	\$ 39.21	\$ 33.27	\$ 34.32	\$ 29.91	\$ 33.11	\$ 29.09
	Unit Cost (\$25 Glass)	\$ 35.48	\$ 28.21	\$ 31.25	\$ 25.31	\$ 26.36	\$ 21.96	\$ 25.15	\$ 21.13

10 Year Project Life	Project Life (years)	10	10	10	10	10	10	10	10
	Sediment Processed (million wet tons)	1.2	1.8	2.4	3.5	3.6	5.3	5.4	7.9
	Capital (\$million)	29.30	32.30	56.23	62.23	70.39	79.39	102.03	115.53
	Annual O&M (\$million)	4.83	6.21	8.42	11.18	11.43	15.57	16.55	22.76
	NPV before Glass Sales (\$million)	66.60	80.25	121.27	148.57	158.67	199.63	229.81	291.26
	Unit Cost (\$2 Glass)	\$ 54.73	\$ 45.09	\$ 49.76	\$ 41.68	\$ 43.30	\$ 37.25	\$ 41.79	\$ 36.21
	Unit Cost (\$25 Glass)	\$ 45.85	\$ 36.21	\$ 40.88	\$ 32.80	\$ 34.42	\$ 28.37	\$ 32.91	\$ 27.33

8 Year Project Life	Project Life (years)	8	8	8	8	8	8	8	8
	Sediment Processed (million wet tons)	1.0	1.4	1.9	2.8	2.9	4.2	4.3	6.3
	Capital (\$million)	29.30	32.30	56.23	62.23	70.39	79.39	102.03	115.53
	Annual O&M (\$million)	4.83	6.21	8.42	11.18	11.43	15.57	16.55	22.76
	NPV before Glass Sales (\$million)	60.52	72.44	110.67	134.50	144.28	180.03	208.99	262.62
	Unit Cost (\$2 Glass)	\$ 62.23	\$ 50.93	\$ 56.83	\$ 47.23	\$ 49.29	\$ 42.06	\$ 47.57	\$ 40.88
	Unit Cost (\$25 Glass)	\$ 52.94	\$ 41.64	\$ 47.54	\$ 37.94	\$ 40.00	\$ 32.77	\$ 38.28	\$ 31.59

7 Year Project Life	Project Life (years)	7	7	7	7	7	7	7	7
	Sediment Processed (million wet tons)	0.8	1.2	1.7	2.5	2.5	3.7	3.8	5.5
	Capital (\$million)	29.30	32.30	56.23	62.23	70.39	79.39	102.03	115.53
	Annual O&M (\$million)	4.83	6.21	8.42	11.18	11.43	15.57	16.55	22.76
	NPV before Glass Sales (\$million)	57.25	68.23	104.97	126.93	136.54	169.49	197.79	247.21
	Unit Cost (\$2 Glass)	\$ 67.33	\$ 54.87	\$ 61.65	\$ 50.98	\$ 53.36	\$ 45.29	\$ 51.50	\$ 44.02
	Unit Cost (\$25 Glass)	\$ 57.82	\$ 45.37	\$ 52.15	\$ 41.48	\$ 43.85	\$ 35.79	\$ 41.99	\$ 34.51

UNIT COST ESTIMATES
PROJECTS IN SERVICE FOR FIXED AMOUNT OF TIME
SEDIMENT FEED 50% SOLIDS

Plant Size, Glass tons/day	1 x 250		2 x 250		2 x 375		3 x 375	
Daily capacity (tons)	540		1,080		1,620		2,430	
Storage Building Size (tons)	n/a	59,400	n/a	118,800	n/a	178,200	n/a	267,300
Days/yr Operation	240	350	240	350	240	350	240	350

15 Year Project Life	Project Life (years)	15	15	15	15	15	15	15	15
	Sediment Processed (million wet tons)	1.9	2.8	3.9	5.7	5.8	8.5	8.7	12.8
	Capital (\$million)	29.30	32.30	56.23	62.23	70.39	79.39	102.03	115.53
	Annual O&M (\$million)	4.97	6.42	8.70	11.59	11.86	16.19	17.18	23.68
	NPV before Glass Sales (\$million)	80.90	98.89	146.58	182.56	193.45	247.42	280.38	361.34
	Unit Cost (\$2 Glass)	\$ 40.97	\$ 34.24	\$ 37.06	\$ 31.56	\$ 32.53	\$ 28.45	\$ 31.36	\$ 27.63
	Unit Cost (\$25 Glass)	\$ 33.61	\$ 26.87	\$ 29.69	\$ 24.19	\$ 25.16	\$ 21.08	\$ 23.40	\$ 19.67

10 Year Project Life	Project Life (years)	10	10	10	10	10	10	10	10
	Sediment Processed (million wet tons)	1.3	1.9	2.6	3.8	3.9	5.7	5.8	8.5
	Capital (\$million)	29.30	32.30	56.23	62.23	70.39	79.39	102.03	115.53
	Annual O&M (\$million)	4.97	6.42	8.70	11.59	11.86	16.19	17.18	23.68
	NPV before Glass Sales (\$million)	67.69	81.84	123.44	151.75	161.94	204.39	234.71	298.40
	Unit Cost (\$2 Glass)	\$ 51.51	\$ 42.59	\$ 46.91	\$ 39.43	\$ 40.94	\$ 35.33	\$ 39.47	\$ 34.31
	Unit Cost (\$25 Glass)	\$ 43.29	\$ 34.36	\$ 38.69	\$ 31.21	\$ 32.71	\$ 27.11	\$ 30.59	\$ 25.43

8 Year Project Life	Project Life (years)	8	8	8	8	8	8	8	8
	Sediment Processed (million wet tons)	1.0	1.5	2.1	3.0	3.1	4.5	4.7	6.8
	Capital (\$million)	29.30	32.30	56.23	62.23	70.39	79.39	102.03	115.53
	Annual O&M (\$million)	4.97	6.42	8.70	11.59	11.86	16.19	17.18	23.68
	NPV before Glass Sales (\$million)	61.43	73.76	112.49	137.16	147.02	184.02	213.09	268.59
	Unit Cost (\$2 Glass)	\$ 58.50	\$ 48.04	\$ 53.50	\$ 44.61	\$ 46.52	\$ 39.82	\$ 44.86	\$ 38.67
	Unit Cost (\$25 Glass)	\$ 49.90	\$ 39.43	\$ 44.90	\$ 36.01	\$ 37.92	\$ 31.22	\$ 35.57	\$ 29.38

7 Year Project Life	Project Life (years)	7	7	7	7	7	7	7	7
	Sediment Processed (million wet tons)	0.9	1.3	1.8	2.6	2.7	4.0	4.1	6.0
	Capital (\$million)	29.30	32.30	56.23	62.23	70.39	79.39	102.03	115.53
	Annual O&M (\$million)	4.97	6.42	8.70	11.59	11.86	16.19	17.18	23.68
	NPV before Glass Sales (\$million)	58.06	69.42	106.60	129.31	138.99	173.06	201.46	252.56
	Unit Cost (\$2 Glass)	\$ 63.24	\$ 51.71	\$ 57.99	\$ 48.11	\$ 50.30	\$ 42.84	\$ 48.52	\$ 41.60
	Unit Cost (\$25 Glass)	\$ 54.44	\$ 42.91	\$ 49.18	\$ 39.30	\$ 41.50	\$ 34.04	\$ 39.01	\$ 32.09

UNIT COST ESTIMATES
PROJECTS IN SERVICE FOR FIXED AMOUNT OF TIME

SEDIMENT FEED 45% SOLIDS

Plant Size, Glass tons/day	1 x 250		2 x 250		2 x 375		3 x 375	
Daily capacity (tons)	600		1,200		1,800		2,700	
Storage Building Size (tons)	n/a	66,000	n/a	132,000	n/a	198,000	n/a	297,000
Days/yr Operation	240	350	240	350	240	350	240	350

15 Year Project Life	Project Life (years)	15	15	15	15	15	15	15	15
	Sediment Processed (million wet tons)	2.2	3.2	4.3	6.3	6.5	9.5	9.7	14.2
	Capital (\$million)	29.30	32.30	56.23	62.23	70.39	79.39	102.03	115.53
	Annual O&M (\$million)	5.14	6.66	9.05	12.09	12.37	16.93	17.95	24.80
	NPV before Glass Sales (\$million)	82.67	101.47	150.12	187.72	198.75	255.16	288.34	372.95
	Unit Cost (\$2 Glass)	\$ 37.70	\$ 31.64	\$ 34.17	\$ 29.22	\$ 30.10	\$ 26.42	\$ 28.97	\$ 25.62
	Unit Cost (\$25 Glass)	\$ 31.06	\$ 25.00	\$ 27.54	\$ 22.59	\$ 23.46	\$ 19.79	\$ 21.02	\$ 17.66

10 Year Project Life	Project Life (years)	10	10	10	10	10	10	10	10
	Sediment Processed (million wet tons)	1.4	2.1	2.9	4.2	4.3	6.3	6.5	9.5
	Capital (\$million)	29.30	32.30	56.23	62.23	70.39	79.39	102.03	115.53
	Annual O&M (\$million)	5.14	6.66	9.05	12.09	12.37	16.93	17.95	24.80
	NPV before Glass Sales (\$million)	69.00	83.76	126.08	155.59	165.88	210.15	240.63	307.03
	Unit Cost (\$2 Glass)	\$ 47.27	\$ 39.24	\$ 43.13	\$ 36.40	\$ 37.76	\$ 32.71	\$ 36.36	\$ 31.72
	Unit Cost (\$25 Glass)	\$ 39.87	\$ 31.84	\$ 35.73	\$ 29.00	\$ 30.36	\$ 25.31	\$ 27.48	\$ 22.84

8 Year Project Life	Project Life (years)	8	8	8	8	8	8	8	8
	Sediment Processed (million wet tons)	1.2	1.7	2.3	3.4	3.5	5.0	5.2	7.6
	Capital (\$million)	29.30	32.30	56.23	62.23	70.39	79.39	102.03	115.53
	Annual O&M (\$million)	5.14	6.66	9.05	12.09	12.37	16.93	17.95	24.80
	NPV before Glass Sales (\$million)	62.53	75.37	114.69	140.37	150.32	188.84	218.04	275.82
	Unit Cost (\$2 Glass)	\$ 53.61	\$ 44.19	\$ 49.11	\$ 41.10	\$ 42.82	\$ 36.79	\$ 41.25	\$ 35.68
	Unit Cost (\$25 Glass)	\$ 45.86	\$ 36.45	\$ 41.36	\$ 33.36	\$ 35.08	\$ 29.05	\$ 31.96	\$ 26.39

7 Year Project Life	Project Life (years)	7	7	7	7	7	7	7	7
	Sediment Processed (million wet tons)	1.0	1.5	2.0	2.9	3.0	4.4	4.5	6.6
	Capital (\$million)	29.30	32.30	56.23	62.23	70.39	79.39	102.03	115.53
	Annual O&M (\$million)	5.14	6.66	9.05	12.09	12.37	16.93	17.95	24.80
	NPV before Glass Sales (\$million)	59.05	70.86	108.57	132.19	141.95	177.38	205.89	259.03
	Unit Cost (\$2 Glass)	\$ 57.89	\$ 47.51	\$ 53.17	\$ 44.27	\$ 46.25	\$ 39.53	\$ 44.56	\$ 38.33
	Unit Cost (\$25 Glass)	\$ 49.97	\$ 39.59	\$ 45.24	\$ 36.35	\$ 38.33	\$ 31.61	\$ 35.06	\$ 28.83

UNIT COST ESTIMATES
PROJECTS IN SERVICE FOR FIXED AMOUNT OF TIME
SEDIMENT FEED 40% SOLIDS

Plant Size, Glass tons/day	1 x 250		2 x 250		2 x 375		3 x 375	
Daily capacity (tons)	675		1,350		2,025		3,038	
Storage Building Size (tons)	n/a	74,250	n/a	148,500	n/a	222,750	n/a	334,125
Days/yr Operation	240	350	240	350	240	350	240	350

15 Year Project Life	Project Life (years)	15	15	15	15	15	15	15	15
	Sediment Processed (million wet tons)	2.4	3.5	4.9	7.1	7.3	10.6	10.9	15.9
	Capital (\$million)	29.30	32.30	56.23	62.23	70.39	79.39	102.03	115.53
	Annual O&M (\$million)	5.35	6.97	9.47	12.71	13.01	17.87	18.91	26.20
	NPV before Glass Sales (\$million)	84.88	104.69	154.54	194.17	205.39	264.84	298.30	387.47
	Unit Cost (\$2 Glass)	\$ 34.42	\$ 29.03	\$ 31.29	\$ 26.88	\$ 27.66	\$ 24.40	\$ 26.59	\$ 23.61
	Unit Cost (\$25 Glass)	\$ 28.52	\$ 23.14	\$ 25.39	\$ 20.99	\$ 21.77	\$ 18.50	\$ 18.63	\$ 15.65

10 Year Project Life	Project Life (years)	10	10	10	10	10	10	10	10
	Sediment Processed (million wet tons)	1.6	2.4	3.2	4.7	4.9	7.1	7.3	10.6
	Capital (\$million)	29.30	32.30	56.23	62.23	70.39	79.39	102.03	115.53
	Annual O&M (\$million)	5.35	6.97	9.47	12.71	13.01	17.87	18.91	26.20
	NPV before Glass Sales (\$million)	70.65	86.16	129.37	160.39	170.82	217.35	248.04	317.83
	Unit Cost (\$2 Glass)	\$ 43.04	\$ 35.90	\$ 39.36	\$ 33.37	\$ 34.58	\$ 30.09	\$ 33.25	\$ 29.12
	Unit Cost (\$25 Glass)	\$ 36.46	\$ 29.32	\$ 32.78	\$ 26.79	\$ 28.00	\$ 23.52	\$ 24.37	\$ 20.24

8 Year Project Life	Project Life (years)	8	8	8	8	8	8	8	8
	Sediment Processed (million wet tons)	1.3	1.9	2.6	3.8	3.9	5.7	5.8	8.5
	Capital (\$million)	29.30	32.30	56.23	62.23	70.39	79.39	102.03	115.53
	Annual O&M (\$million)	5.35	6.97	9.47	12.71	13.01	17.87	18.91	26.20
	NPV before Glass Sales (\$million)	63.91	77.38	117.45	144.39	154.45	194.86	224.24	284.86
	Unit Cost (\$2 Glass)	\$ 48.71	\$ 40.34	\$ 44.71	\$ 37.60	\$ 39.13	\$ 33.77	\$ 37.64	\$ 32.69
	Unit Cost (\$25 Glass)	\$ 41.83	\$ 33.46	\$ 37.83	\$ 30.72	\$ 32.24	\$ 26.89	\$ 28.35	\$ 23.39

7 Year Project Life	Project Life (years)	7	7	7	7	7	7	7	7
	Sediment Processed (million wet tons)	1.1	1.7	2.3	3.3	3.4	5.0	5.1	7.4
	Capital (\$million)	29.30	32.30	56.23	62.23	70.39	79.39	102.03	115.53
	Annual O&M (\$million)	5.35	6.97	9.47	12.71	13.01	17.87	18.91	26.20
	NPV before Glass Sales (\$million)	60.28	72.66	111.04	135.78	145.65	182.77	211.44	267.13
	Unit Cost (\$2 Glass)	\$ 52.55	\$ 43.32	\$ 48.35	\$ 40.44	\$ 42.20	\$ 36.23	\$ 40.61	\$ 35.07
	Unit Cost (\$25 Glass)	\$ 45.51	\$ 36.28	\$ 41.30	\$ 33.40	\$ 35.16	\$ 29.19	\$ 31.10	\$ 25.56

UNIT COST ESTIMATES
PROJECTS IN SERVICE FOR FIXED AMOUNT OF TIME

SEDIMENT FEED 35% SOLIDS

Plant Size, Glass tons/day	1 x 250		2 x 250		2 x 375		3 x 375	
Daily capacity (tons)	771		1,542		2,313		3,470	
Storage Building Size (tons)	n/a	84,810	n/a	169,620	n/a	254,430	n/a	381,645
Days/yr Operation	240	350	240	350	240	350	240	350

15 Year Project Life	Project Life (years)	15	15	15	15	15	15	15	15
	Sediment Processed (million wet tons)	2.8	4.0	5.6	8.1	8.3	12.1	12.5	18.2
	Capital (\$million)	29.30	32.30	56.23	62.23	70.39	79.39	102.03	115.53
	Annual O&M (\$million)	5.63	7.37	10.02	13.51	13.83	19.06	20.14	27.99
	NPV before Glass Sales (\$million)	87.71	108.83	160.21	202.44	213.89	277.23	311.05	406.06
	Unit Cost (\$2 Glass)	\$ 31.15	\$ 26.44	\$ 28.41	\$ 24.56	\$ 25.24	\$ 22.38	\$ 24.21	\$ 21.60
	Unit Cost (\$25 Glass)	\$ 25.99	\$ 21.28	\$ 23.25	\$ 19.40	\$ 20.08	\$ 17.22	\$ 16.25	\$ 13.64

10 Year Project Life	Project Life (years)	10	10	10	10	10	10	10	10
	Sediment Processed (million wet tons)	1.9	2.7	3.7	5.4	5.6	8.1	8.3	12.1
	Capital (\$million)	29.30	32.30	56.23	62.23	70.39	79.39	102.03	115.53
	Annual O&M (\$million)	5.63	7.37	10.02	13.51	13.83	19.06	20.14	27.99
	NPV before Glass Sales (\$million)	72.75	89.23	133.58	166.53	177.14	226.57	257.52	331.66
	Unit Cost (\$2 Glass)	\$ 38.82	\$ 32.57	\$ 35.59	\$ 30.36	\$ 31.41	\$ 27.49	\$ 30.15	\$ 26.54
	Unit Cost (\$25 Glass)	\$ 33.06	\$ 26.81	\$ 29.84	\$ 24.60	\$ 25.65	\$ 21.73	\$ 21.27	\$ 17.66

8 Year Project Life	Project Life (years)	8	8	8	8	8	8	8	8
	Sediment Processed (million wet tons)	1.5	2.2	3.0	4.3	4.4	6.5	6.7	9.7
	Capital (\$million)	29.30	32.30	56.23	62.23	70.39	79.39	102.03	115.53
	Annual O&M (\$million)	5.63	7.37	10.02	13.51	13.83	19.06	20.14	27.99
	NPV before Glass Sales (\$million)	65.67	79.95	120.98	149.53	159.74	202.58	232.18	296.44
	Unit Cost (\$2 Glass)	\$ 43.84	\$ 36.51	\$ 40.34	\$ 34.11	\$ 35.45	\$ 30.76	\$ 34.05	\$ 29.71
	Unit Cost (\$25 Glass)	\$ 37.81	\$ 30.49	\$ 34.31	\$ 28.08	\$ 29.42	\$ 24.73	\$ 24.76	\$ 20.42

7 Year Project Life	Project Life (years)	7	7	7	7	7	7	7	7
	Sediment Processed (million wet tons)	1.3	1.9	2.6	3.8	3.9	5.7	5.8	8.5
	Capital (\$million)	29.30	32.30	56.23	62.23	70.39	79.39	102.03	115.53
	Annual O&M (\$million)	5.63	7.37	10.02	13.51	13.83	19.06	20.14	27.99
	NPV before Glass Sales (\$million)	61.86	74.96	114.20	140.39	150.39	189.68	218.55	277.49
	Unit Cost (\$2 Glass)	\$ 47.22	\$ 39.15	\$ 43.55	\$ 36.63	\$ 38.17	\$ 32.94	\$ 36.67	\$ 31.82
	Unit Cost (\$25 Glass)	\$ 41.06	\$ 32.98	\$ 37.38	\$ 30.46	\$ 32.00	\$ 26.77	\$ 27.16	\$ 22.31

UNIT COST ESTIMATES
PROJECTS IN SERVICE FOR FIXED AMOUNT OF TIME
SEDIMENT FEED 30% SOLIDS

Plant Size, Glass tons/day	1 x 250		2 x 250		2 x 375		3 x 375	
Daily capacity (tons)	804		1,608		2,412		3,618	
Storage Building Size (tons)	n/a	88,440	n/a	176,880	n/a	265,320	n/a	397,980
Days/yr Operation	240	350	240	350	240	350	240	350

15 Year Project Life	Project Life (years)	15	15	15	15	15	15	15	15
	Sediment Processed (million wet tons)	2.9	4.2	5.8	8.4	8.7	12.7	13.0	19.0
	Capital (\$million)	29.30	32.30	56.23	62.23	70.39	79.39	102.03	115.53
	Annual O&M (\$million)	5.74	7.54	10.24	13.84	14.16	19.55	20.64	28.73
	NPV before Glass Sales (\$million)	88.88	110.53	162.55	205.85	217.40	282.35	316.32	413.74
	Unit Cost (\$2 Glass)	\$ 30.28	\$ 25.76	\$ 27.65	\$ 23.95	\$ 24.61	\$ 21.87	\$ 23.59	\$ 21.09
	Unit Cost (\$25 Glass)	\$ 25.33	\$ 20.81	\$ 22.70	\$ 19.01	\$ 19.66	\$ 16.92	\$ 15.64	\$ 13.13

10 Year Project Life	Project Life (years)	10	10	10	10	10	10	10	10
	Sediment Processed (million wet tons)	1.9	2.8	3.9	5.6	5.8	8.4	8.7	12.7
	Capital (\$million)	29.30	32.30	56.23	62.23	70.39	79.39	102.03	115.53
	Annual O&M (\$million)	5.74	7.54	10.24	13.84	14.16	19.55	20.64	28.73
	NPV before Glass Sales (\$million)	73.63	90.50	135.33	169.07	179.76	230.38	261.44	337.38
	Unit Cost (\$2 Glass)	\$ 37.68	\$ 31.68	\$ 34.59	\$ 29.56	\$ 30.57	\$ 26.81	\$ 29.34	\$ 25.87
	Unit Cost (\$25 Glass)	\$ 32.15	\$ 26.16	\$ 29.06	\$ 24.04	\$ 25.05	\$ 21.29	\$ 20.46	\$ 16.99

8 Year Project Life	Project Life (years)	8	8	8	8	8	8	8	8
	Sediment Processed (million wet tons)	1.5	2.3	3.1	4.5	4.6	6.8	6.9	10.1
	Capital (\$million)	29.30	32.30	56.23	62.23	70.39	79.39	102.03	115.53
	Annual O&M (\$million)	5.74	7.54	10.24	13.84	14.16	19.55	20.64	28.73
	NPV before Glass Sales (\$million)	66.40	81.01	122.43	151.66	161.93	205.77	235.46	301.22
	Unit Cost (\$2 Glass)	\$ 42.51	\$ 35.48	\$ 39.15	\$ 33.18	\$ 34.46	\$ 29.97	\$ 33.09	\$ 28.93
	Unit Cost (\$25 Glass)	\$ 36.73	\$ 29.71	\$ 33.38	\$ 27.40	\$ 28.69	\$ 24.19	\$ 23.80	\$ 19.64

7 Year Project Life	Project Life (years)	7	7	7	7	7	7	7	7
	Sediment Processed (million wet tons)	1.4	2.0	2.7	3.9	4.1	5.9	6.1	8.9
	Capital (\$million)	29.30	32.30	56.23	62.23	70.39	79.39	102.03	115.53
	Annual O&M (\$million)	5.74	7.54	10.24	13.84	14.16	19.55	20.64	28.73
	NPV before Glass Sales (\$million)	62.52	75.91	115.50	142.30	152.35	192.54	221.49	281.78
	Unit Cost (\$2 Glass)	\$ 45.77	\$ 38.02	\$ 42.24	\$ 35.61	\$ 37.08	\$ 32.07	\$ 35.61	\$ 30.96
	Unit Cost (\$25 Glass)	\$ 39.86	\$ 32.11	\$ 36.33	\$ 29.69	\$ 31.17	\$ 26.16	\$ 26.11	\$ 21.46

UNIT COST ESTIMATES
PROJECTS IN SERVICE FOR FIXED AMOUNT OF DREDGING

SEDIMENT FEED 55% SOLIDS

Plant Size, Glass tons/day	1 x 250		2 x 250		2 x 375		3 x 375	
Daily capacity (tons)	500		1,000		1,500		2,250	
Storage Building Size (tons)	n/a	55,000	n/a	110,000	n/a	165,000	n/a	247,500
Days/yr Operation	240	350	240	350	240	350	240	350

3,575,000 Dry Ton Project	Project Life (years)	54	37	27	19	18	12	12	8
	Sediment Processed (million wet tons)	6.5	6.5	6.5	6.5	6.5	6.5	6.5	6.5
	Capital (\$million)	29.30	32.30	56.23	62.23	70.39	79.39	102.03	115.53
	Annual O&M (\$million)	4.83	6.21	8.42	11.18	11.43	15.57	16.55	22.76
	NPV before Glass Sales (\$million)	119.03	136.22	179.75	195.50	204.29	220.60	249.04	266.41
	Unit Cost (\$2 Glass)	\$ 17.97	\$ 20.51	\$ 27.11	\$ 29.43	\$ 30.78	\$ 33.21	\$ 37.58	\$ 40.18
	Unit Cost (\$25 Glass)	\$ 14.03	\$ 15.32	\$ 20.89	\$ 22.05	\$ 23.32	\$ 24.78	\$ 29.09	\$ 30.95

2,420,000 Dry Ton Project	Project Life (years)	37	25	18	13	12	8	8	6
	Sediment Processed (million wet tons)	4.4	4.4	4.4	4.4	4.4	4.4	4.4	4.4
	Capital (\$million)	29.30	32.30	56.23	62.23	70.39	79.39	102.03	115.53
	Annual O&M (\$million)	4.83	6.21	8.42	11.18	11.43	15.57	16.55	22.76
	NPV before Glass Sales (\$million)	109.76	120.08	155.82	164.76	173.10	183.92	210.60	224.13
	Unit Cost (\$2 Glass)	\$ 24.49	\$ 26.73	\$ 34.77	\$ 36.72	\$ 38.60	\$ 41.00	\$ 47.06	\$ 50.08
	Unit Cost (\$25 Glass)	\$ 19.27	\$ 20.26	\$ 27.35	\$ 28.33	\$ 30.15	\$ 31.79	\$ 37.80	\$ 40.26

1,980,000 Dry Ton Project	Project Life (years)	30	21	15	10	10	7	7	5
	Sediment Processed (million wet tons)	3.6	3.6	3.6	3.6	3.6	3.6	3.6	3.6
	Capital (\$million)	29.30	32.30	56.23	62.23	70.39	79.39	102.03	115.53
	Annual O&M (\$million)	4.83	6.21	8.42	11.18	11.43	15.57	16.55	22.76
	NPV before Glass Sales (\$million)	103.55	110.97	143.65	150.48	158.67	167.95	193.93	206.52
	Unit Cost (\$2 Glass)	\$ 28.25	\$ 30.21	\$ 39.21	\$ 41.03	\$ 43.30	\$ 45.82	\$ 53.04	\$ 56.49
	Unit Cost (\$25 Glass)	\$ 22.36	\$ 23.13	\$ 31.25	\$ 32.21	\$ 34.42	\$ 36.28	\$ 43.46	\$ 46.43

1,500,000 Dry Ton Project	Project Life (years)	23	16	11	8	8	5	5	3
	Sediment Processed (million wet tons)	2.7	2.7	2.7	2.7	2.7	2.7	2.7	2.7
	Capital (\$million)	29.30	32.30	56.23	62.23	70.39	79.39	102.03	115.53
	Annual O&M (\$million)	4.83	6.21	8.42	11.18	11.43	15.57	16.55	22.76
	NPV before Glass Sales (\$million)	94.03	98.44	127.92	132.96	141.05	149.12	174.32	186.29
	Unit Cost (\$2 Glass)	\$ 33.89	\$ 35.41	\$ 46.16	\$ 47.94	\$ 50.90	\$ 53.81	\$ 63.05	\$ 67.41
	Unit Cost (\$25 Glass)	\$ 27.11	\$ 27.55	\$ 37.54	\$ 38.60	\$ 41.52	\$ 43.90	\$ 53.10	\$ 57.08

Note: 1,500,000 Dry tons is equivalent to 2,720,000 wet tons at 55% solids
1,980,000 Dry tons is equivalent to 3,600,000 wet tons at 55% solids
2,420,000 Dry tons is equivalent to 4,400,000 wet tons at 55% solids
3,575,000 Dry tons is equivalent to 6,500,000 wet tons at 55% solids

UNIT COST ESTIMATES
PROJECTS IN SERVICE FOR FIXED AMOUNT OF DREDGING

SEDIMENT FEED 50% SOLIDS

Plant Size, Glass tons/day	1 x 250		2 x 250		2 x 375		3 x 375	
Daily capacity (tons)	540		1,080		1,620		2,430	
Storage Building Size (tons)	n/a	59,400	n/a	118,800	n/a	178,200	n/a	267,300
Days/yr Operation	240	350	240	350	240	350	240	350

3,575,000 Dry Ton Project	Project Life (years)	55	38	28	19	18	13	12	8
	Sediment Processed (million wet tons)	7.2	7.2	7.2	7.2	7.2	7.2	7.2	7.2
	Capital (\$million)	29.30	32.30	56.23	62.23	70.39	79.39	102.03	115.53
	Annual O&M (\$million)	4.97	6.42	8.70	11.59	11.86	16.19	17.18	23.68
	NPV before Glass Sales (\$million)	121.98	140.35	185.00	201.96	210.83	228.16	256.74	274.89
	Unit Cost (\$2 Glass)	\$ 16.75	\$ 19.22	\$ 25.38	\$ 27.66	\$ 28.89	\$ 31.24	\$ 35.17	\$ 37.65
	Unit Cost (\$25 Glass)	\$ 13.15	\$ 14.48	\$ 19.67	\$ 20.87	\$ 22.03	\$ 23.48	\$ 26.73	\$ 28.44

2,420,000 Dry Ton Project	Project Life (years)	37	26	19	13	12	9	8	6
	Sediment Processed (million wet tons)	4.8	4.8	4.8	4.8	4.8	4.8	4.8	4.8
	Capital (\$million)	29.30	32.30	56.23	62.23	70.39	79.39	102.03	115.53
	Annual O&M (\$million)	4.97	6.42	8.70	11.59	11.86	16.19	17.18	23.68
	NPV before Glass Sales (\$million)	112.65	123.83	160.32	169.95	178.33	189.68	216.46	230.36
	Unit Cost (\$2 Glass)	\$ 22.86	\$ 25.07	\$ 32.53	\$ 34.44	\$ 36.17	\$ 38.45	\$ 43.92	\$ 46.74
	Unit Cost (\$25 Glass)	\$ 18.08	\$ 19.14	\$ 25.71	\$ 26.71	\$ 28.38	\$ 29.95	\$ 34.69	\$ 36.94

1,980,000 Dry Ton Project	Project Life (years)	31	21	15	10	10	7	7	5
	Sediment Processed (million wet tons)	4.0	4.0	4.0	4.0	4.0	4.0	4.0	4.0
	Capital (\$million)	29.30	32.30	56.23	62.23	70.39	79.39	102.03	115.53
	Annual O&M (\$million)	4.97	6.42	8.70	11.59	11.86	16.19	17.18	23.68
	NPV before Glass Sales (\$million)	106.33	114.44	147.71	155.02	163.25	172.88	198.94	211.78
	Unit Cost (\$2 Glass)	\$ 26.38	\$ 28.33	\$ 36.66	\$ 38.44	\$ 40.51	\$ 42.89	\$ 49.41	\$ 52.61
	Unit Cost (\$25 Glass)	\$ 20.98	\$ 21.83	\$ 29.34	\$ 30.30	\$ 32.32	\$ 34.09	\$ 39.86	\$ 42.57

1,500,000 Dry Ton Project	Project Life (years)	23	16	12	8	8	5	5	4
	Sediment Processed (million wet tons)	3.0	3.0	3.0	3.0	3.0	3.0	3.0	3.0
	Capital (\$million)	29.30	32.30	56.23	62.23	70.39	79.39	102.03	115.53
	Annual O&M (\$million)	4.97	6.42	8.70	11.59	11.86	16.19	17.18	23.68
	NPV before Glass Sales (\$million)	96.59	101.46	131.35	136.67	144.78	153.05	178.31	190.42
	Unit Cost (\$2 Glass)	\$ 31.65	\$ 33.19	\$ 43.09	\$ 44.81	\$ 47.51	\$ 50.22	\$ 58.57	\$ 62.58
	Unit Cost (\$25 Glass)	\$ 25.43	\$ 25.96	\$ 35.15	\$ 36.19	\$ 38.85	\$ 41.06	\$ 48.65	\$ 52.27

Note: 1,500,000 Dry tons is equivalent to 2,720,000 wet tons at 55% solids
1,980,000 Dry tons is equivalent to 3,600,000 wet tons at 55% solids
2,420,000 Dry tons is equivalent to 4,400,000 wet tons at 55% solids
3,575,000 Dry tons is equivalent to 6,500,000 wet tons at 55% solids

UNIT COST ESTIMATES
PROJECTS IN SERVICE FOR FIXED AMOUNT OF DREDGING

SEDIMENT FEED 45% SOLIDS

Plant Size, Glass tons/day	1 x 250		2 x 250		2 x 375		3 x 375	
Daily capacity (tons)	600		1,200		1,800		2,700	
Storage Building Size (tons)	n/a	66,000	n/a	132,000	n/a	198,000	n/a	297,000
Days/yr Operation	240	350	240	350	240	350	240	350

3,575,000 Dry Ton Project	Project Life (years)	55	38	28	19	18	13	12	8
	Sediment Processed (million wet tons)	7.9	7.9	7.9	7.9	7.9	7.9	7.9	7.9
	Capital (\$million)	29.30	32.30	56.23	62.23	70.39	79.39	102.03	115.53
	Annual O&M (\$million)	5.14	6.66	9.05	12.09	12.37	16.93	17.95	24.80
	NPV before Glass Sales (\$million)	125.16	144.53	190.04	207.95	216.89	235.01	263.64	282.42
	Unit Cost (\$2 Glass)	\$ 15.47	\$ 17.82	\$ 23.47	\$ 25.64	\$ 26.76	\$ 28.97	\$ 32.45	\$ 34.75
	Unit Cost (\$25 Glass)	\$ 12.23	\$ 13.56	\$ 18.34	\$ 19.54	\$ 20.59	\$ 21.99	\$ 24.01	\$ 25.54

2,420,000 Dry Ton Project	Project Life (years)	37	26	19	13	12	9	8	6
	Sediment Processed (million wet tons)	5.4	5.4	5.4	5.4	5.4	5.4	5.4	5.4
	Capital (\$million)	29.30	32.30	56.23	62.23	70.39	79.39	102.03	115.53
	Annual O&M (\$million)	5.14	6.66	9.05	12.09	12.37	16.93	17.95	24.80
	NPV before Glass Sales (\$million)	115.50	127.37	164.39	174.57	182.98	194.76	221.56	235.78
	Unit Cost (\$2 Glass)	\$ 21.10	\$ 23.22	\$ 30.04	\$ 31.86	\$ 33.42	\$ 35.55	\$ 40.40	\$ 42.99
	Unit Cost (\$25 Glass)	\$ 16.80	\$ 17.88	\$ 23.90	\$ 24.90	\$ 26.41	\$ 27.90	\$ 31.17	\$ 33.19

1,980,000 Dry Ton Project	Project Life (years)	31	21	15	10	10	7	7	5
	Sediment Processed (million wet tons)	4.4	4.4	4.4	4.4	4.4	4.4	4.4	4.4
	Capital (\$million)	29.30	32.30	56.23	62.23	70.39	79.39	102.03	115.53
	Annual O&M (\$million)	5.14	6.66	9.05	12.09	12.37	16.93	17.95	24.80
	NPV before Glass Sales (\$million)	108.97	117.63	151.29	159.00	167.25	177.19	203.27	216.33
	Unit Cost (\$2 Glass)	\$ 24.34	\$ 26.22	\$ 33.81	\$ 35.50	\$ 37.37	\$ 39.58	\$ 45.37	\$ 48.29
	Unit Cost (\$25 Glass)	\$ 19.48	\$ 20.37	\$ 27.22	\$ 28.18	\$ 30.00	\$ 31.66	\$ 35.81	\$ 38.25

1,500,000 Dry Ton Project	Project Life (years)	23	16	12	8	8	5	5	4
	Sediment Processed (million wet tons)	3.3	3.3	3.3	3.3	3.3	3.3	3.3	3.3
	Capital (\$million)	29.30	32.30	56.23	62.23	70.39	79.39	102.03	115.53
	Annual O&M (\$million)	5.14	6.66	9.05	12.09	12.37	16.93	17.95	24.80
	NPV before Glass Sales (\$million)	98.89	104.14	134.29	139.86	147.98	156.45	181.71	193.95
	Unit Cost (\$2 Glass)	\$ 29.18	\$ 30.68	\$ 39.66	\$ 41.28	\$ 43.72	\$ 46.22	\$ 53.65	\$ 57.29
	Unit Cost (\$25 Glass)	\$ 23.58	\$ 24.17	\$ 32.52	\$ 33.53	\$ 35.92	\$ 37.98	\$ 43.73	\$ 46.98

Note: 1,500,000 Dry tons is equivalent to 2,720,000 wet tons at 55% solids
1,980,000 Dry tons is equivalent to 3,600,000 wet tons at 55% solids
2,420,000 Dry tons is equivalent to 4,400,000 wet tons at 55% solids
3,575,000 Dry tons is equivalent to 6,500,000 wet tons at 55% solids

UNIT COST ESTIMATES
PROJECTS IN SERVICE FOR FIXED AMOUNT OF DREDGING

SEDIMENT FEED 40% SOLIDS

Plant Size, Glass tons/day	1 x 250		2 x 250		2 x 375		3 x 375	
Daily capacity (tons)	675		1,350		2,025		3,038	
Storage Building Size (tons)	n/a	74,250	n/a	148,500	n/a	222,750	n/a	334,125
Days/yr Operation	240	350	240	350	240	350	240	350

3,575,000 Dry Ton Project	Project Life (years)	55	38	28	19	18	13	12	8
	Sediment Processed (million wet tons)	8.9	8.9	8.9	8.9	8.9	8.9	8.9	8.9
	Capital (\$million)	29.30	32.30	56.23	62.23	70.39	79.39	102.03	115.53
	Annual O&M (\$million)	5.35	6.97	9.47	12.71	13.01	17.87	18.91	26.20
	NPV before Glass Sales (\$million)	129.14	149.77	196.35	215.44	224.46	243.58	272.28	291.83
	Unit Cost (\$2 Glass)	\$ 14.20	\$ 16.43	\$ 21.57	\$ 23.63	\$ 24.64	\$ 26.71	\$ 29.73	\$ 31.85
	Unit Cost (\$25 Glass)	\$ 11.32	\$ 12.63	\$ 17.00	\$ 18.21	\$ 19.15	\$ 20.51	\$ 21.28	\$ 22.65

2,420,000 Dry Ton Project	Project Life (years)	37	26	19	13	12	9	8	6
	Sediment Processed (million wet tons)	6.1	6.1	6.1	6.1	6.1	6.1	6.1	6.1
	Capital (\$million)	29.30	32.30	56.23	62.23	70.39	79.39	102.03	115.53
	Annual O&M (\$million)	5.35	6.97	9.47	12.71	13.01	17.87	18.91	26.20
	NPV before Glass Sales (\$million)	119.08	131.80	169.49	180.34	188.80	201.11	227.95	242.56
	Unit Cost (\$2 Glass)	\$ 19.35	\$ 21.37	\$ 27.54	\$ 29.27	\$ 30.67	\$ 32.65	\$ 36.87	\$ 39.24
	Unit Cost (\$25 Glass)	\$ 15.53	\$ 16.63	\$ 22.09	\$ 23.09	\$ 24.44	\$ 25.85	\$ 27.65	\$ 29.44

1,980,000 Dry Ton Project	Project Life (years)	31	21	15	10	10	7	7	5
	Sediment Processed (million wet tons)	5.0	5.0	5.0	5.0	5.0	5.0	5.0	5.0
	Capital (\$million)	29.30	32.30	56.23	62.23	70.39	79.39	102.03	115.53
	Annual O&M (\$million)	5.35	6.97	9.47	12.71	13.01	17.87	18.91	26.20
	NPV before Glass Sales (\$million)	112.28	121.61	155.77	163.97	172.26	182.57	208.68	222.01
	Unit Cost (\$2 Glass)	\$ 22.31	\$ 24.11	\$ 30.96	\$ 32.56	\$ 34.23	\$ 36.27	\$ 41.33	\$ 43.98
	Unit Cost (\$25 Glass)	\$ 17.99	\$ 18.91	\$ 25.10	\$ 26.05	\$ 27.68	\$ 29.23	\$ 31.77	\$ 33.94

1,500,000 Dry Ton Project	Project Life (years)	23	16	12	8	8	5	5	4
	Sediment Processed (million wet tons)	3.8	3.8	3.8	3.8	3.8	3.8	3.8	3.8
	Capital (\$million)	29.30	32.30	56.23	62.23	70.39	79.39	102.03	115.53
	Annual O&M (\$million)	5.35	6.97	9.47	12.71	13.01	17.87	18.91	26.20
	NPV before Glass Sales (\$million)	101.78	107.49	137.96	143.85	152.00	160.69	185.97	198.37
	Unit Cost (\$2 Glass)	\$ 26.71	\$ 28.16	\$ 36.24	\$ 37.76	\$ 39.93	\$ 42.21	\$ 48.73	\$ 52.00
	Unit Cost (\$25 Glass)	\$ 21.73	\$ 22.38	\$ 29.89	\$ 30.87	\$ 33.00	\$ 34.89	\$ 38.80	\$ 41.69

Note: 1,500,000 Dry tons is equivalent to 2,720,000 wet tons at 55% solids
1,980,000 Dry tons is equivalent to 3,600,000 wet tons at 55% solids
2,420,000 Dry tons is equivalent to 4,400,000 wet tons at 55% solids
3,575,000 Dry tons is equivalent to 6,500,000 wet tons at 55% solids

UNIT COST ESTIMATES
PROJECTS IN SERVICE FOR FIXED AMOUNT OF DREDGING

SEDIMENT FEED 35% SOLIDS

Plant Size, Glass tons/day	1 x 250		2 x 250		2 x 375		3 x 375	
Daily capacity (tons)	771		1,542		2,313		3,470	
Storage Building Size (tons)	n/a	84,810	n/a	169,620	n/a	254,430	n/a	381,645
Days/yr Operation	240	350	240	350	240	350	240	350

3,575,000 Dry Ton Project	Project Life (years)	55	38	28	19	18	13	12	8
	Sediment Processed (million wet tons)	10.2	10.2	10.2	10.2	10.2	10.2	10.2	10.2
	Capital (\$million)	29.30	32.30	56.23	62.23	70.39	79.39	102.03	115.53
	Annual O&M (\$million)	5.63	7.37	10.02	13.51	13.83	19.06	20.14	27.99
	NPV before Glass Sales (\$million)	134.24	156.49	204.47	225.09	234.22	254.62	283.41	303.97
	Unit Cost (\$2 Glass)	\$ 12.92	\$ 15.03	\$ 19.67	\$ 21.62	\$ 22.51	\$ 24.46	\$ 27.01	\$ 28.96
	Unit Cost (\$25 Glass)	\$ 10.40	\$ 11.71	\$ 15.67	\$ 16.87	\$ 17.71	\$ 19.02	\$ 18.57	\$ 19.75

2,420,000 Dry Ton Project	Project Life (years)	37	26	19	13	12	9	8	6
	Sediment Processed (million wet tons)	6.9	6.9	6.9	6.9	6.9	6.9	6.9	6.9
	Capital (\$million)	29.30	32.30	56.23	62.23	70.39	79.39	102.03	115.53
	Annual O&M (\$million)	5.63	7.37	10.02	13.51	13.83	19.06	20.14	27.99
	NPV before Glass Sales (\$million)	123.67	137.51	176.06	187.79	196.31	209.30	236.19	251.31
	Unit Cost (\$2 Glass)	\$ 17.60	\$ 19.53	\$ 25.05	\$ 26.69	\$ 27.92	\$ 29.75	\$ 33.36	\$ 35.50
	Unit Cost (\$25 Glass)	\$ 14.25	\$ 15.37	\$ 20.27	\$ 21.28	\$ 22.46	\$ 23.80	\$ 24.13	\$ 25.70

1,980,000 Dry Ton Project	Project Life (years)	31	21	15	10	10	7	7	5
	Sediment Processed (million wet tons)	5.7	5.7	5.7	5.7	5.7	5.7	5.7	5.7
	Capital (\$million)	29.30	32.30	56.23	62.23	70.39	79.39	102.03	115.53
	Annual O&M (\$million)	5.63	7.37	10.02	13.51	13.83	19.06	20.14	27.99
	NPV before Glass Sales (\$million)	116.53	126.73	161.54	170.39	178.72	189.52	215.66	229.35
	Unit Cost (\$2 Glass)	\$ 20.27	\$ 22.01	\$ 28.11	\$ 29.62	\$ 31.09	\$ 32.97	\$ 37.29	\$ 39.67
	Unit Cost (\$25 Glass)	\$ 16.49	\$ 17.45	\$ 22.98	\$ 23.93	\$ 25.36	\$ 26.80	\$ 27.74	\$ 29.63

1,500,000 Dry Ton Project	Project Life (years)	23	16	12	8	8	5	5	4
	Sediment Processed (million wet tons)	4.3	4.3	4.3	4.3	4.3	4.3	4.3	4.3
	Capital (\$million)	29.30	32.30	56.23	62.23	70.39	79.39	102.03	115.53
	Annual O&M (\$million)	5.63	7.37	10.02	13.51	13.83	19.06	20.14	27.99
	NPV before Glass Sales (\$million)	105.49	111.81	142.71	149.01	157.17	166.16	191.47	204.08
	Unit Cost (\$2 Glass)	\$ 24.24	\$ 25.65	\$ 32.82	\$ 34.24	\$ 36.15	\$ 38.21	\$ 43.81	\$ 46.72
	Unit Cost (\$25 Glass)	\$ 19.88	\$ 20.58	\$ 27.26	\$ 28.21	\$ 30.08	\$ 31.80	\$ 33.89	\$ 36.41

Note: 1,500,000 Dry tons is equivalent to 2,720,000 wet tons at 55% solids
1,980,000 Dry tons is equivalent to 3,600,000 wet tons at 55% solids
2,420,000 Dry tons is equivalent to 4,400,000 wet tons at 55% solids
3,575,000 Dry tons is equivalent to 6,500,000 wet tons at 55% solids

UNIT COST ESTIMATES
PROJECTS IN SERVICE FOR FIXED AMOUNT OF DREDGING

SEDIMENT FEED 30% SOLIDS

Plant Size, Glass tons/day	1 x 250		2 x 250		2 x 375		3 x 375	
Daily capacity (tons)	804		1,608		2,412		3,618	
Storage Building Size (tons)	n/a	88,440	n/a	176,880	n/a	265,320	n/a	397,980
Days/yr Operation	240	350	240	350	240	350	240	350

3,575,000 Dry Ton Project	Project Life (years)	62	42	31	21	21	14	14	9
	Sediment Processed (million wet tons)	11.9	11.9	11.9	11.9	11.9	11.9	11.9	11.9
	Capital (\$million)	29.30	32.30	56.23	62.23	70.39	79.39	102.03	115.53
	Annual O&M (\$million)	5.74	7.54	10.24	13.84	14.16	19.55	20.64	28.73
	NPV before Glass Sales (\$million)	138.47	163.95	215.68	240.47	249.91	274.06	303.56	327.09
	Unit Cost (\$2 Glass)	\$ 11.43	\$ 13.50	\$ 17.79	\$ 19.80	\$ 20.59	\$ 22.56	\$ 24.76	\$ 26.67
	Unit Cost (\$25 Glass)	\$ 9.23	\$ 10.55	\$ 14.18	\$ 15.45	\$ 16.19	\$ 17.52	\$ 16.58	\$ 17.67

2,420,000 Dry Ton Project	Project Life (years)	42	29	21	14	14	10	9	6
	Sediment Processed (million wet tons)	8.1	8.1	8.1	8.1	8.1	8.1	8.1	8.1
	Capital (\$million)	29.30	32.30	56.23	62.23	70.39	79.39	102.03	115.53
	Annual O&M (\$million)	5.74	7.54	10.24	13.84	14.16	19.55	20.64	28.73
	NPV before Glass Sales (\$million)	129.17	145.82	187.21	201.45	210.14	225.12	252.51	269.03
	Unit Cost (\$2 Glass)	\$ 15.75	\$ 17.75	\$ 22.83	\$ 24.54	\$ 25.61	\$ 27.42	\$ 30.52	\$ 32.51
	Unit Cost (\$25 Glass)	\$ 12.78	\$ 13.99	\$ 18.45	\$ 19.52	\$ 20.55	\$ 21.84	\$ 21.50	\$ 22.87

1,980,000 Dry Ton Project	Project Life (years)	34	23	17	12	11	8	8	5
	Sediment Processed (million wet tons)	6.6	6.6	6.6	6.6	6.6	6.6	6.6	6.6
	Capital (\$million)	29.30	32.30	56.23	62.23	70.39	79.39	102.03	115.53
	Annual O&M (\$million)	5.74	7.54	10.24	13.84	14.16	19.55	20.64	28.73
	NPV before Glass Sales (\$million)	122.47	135.04	172.16	182.80	191.25	203.41	229.97	244.55
	Unit Cost (\$2 Glass)	\$ 18.26	\$ 20.10	\$ 25.67	\$ 27.24	\$ 28.51	\$ 30.32	\$ 34.03	\$ 36.19
	Unit Cost (\$25 Glass)	\$ 14.87	\$ 15.94	\$ 20.94	\$ 21.92	\$ 23.16	\$ 24.51	\$ 24.65	\$ 26.28

1,500,000 Dry Ton Project	Project Life (years)	26	18	13	9	9	6	6	4
	Sediment Processed (million wet tons)	5.0	5.0	5.0	5.0	5.0	5.0	5.0	5.0
	Capital (\$million)	29.30	32.30	56.23	62.23	70.39	79.39	102.03	115.53
	Annual O&M (\$million)	5.74	7.54	10.24	13.84	14.16	19.55	20.64	28.73
	NPV before Glass Sales (\$million)	111.68	119.70	152.22	159.57	167.80	177.54	203.16	216.22
	Unit Cost (\$2 Glass)	\$ 21.99	\$ 23.53	\$ 29.99	\$ 31.42	\$ 33.07	\$ 34.98	\$ 39.78	\$ 42.36
	Unit Cost (\$25 Glass)	\$ 18.03	\$ 18.87	\$ 24.82	\$ 25.76	\$ 27.37	\$ 28.92	\$ 30.00	\$ 32.15

Note: 1,500,000 Dry tons is equivalent to 2,720,000 wet tons at 55% solids
1,980,000 Dry tons is equivalent to 3,600,000 wet tons at 55% solids
2,420,000 Dry tons is equivalent to 4,400,000 wet tons at 55% solids
3,575,000 Dry tons is equivalent to 6,500,000 wet tons at 55% solids

Appendix B - Drawings



MATCHLINE, SEE DWG. GA01-01 FOR CONTINUATION

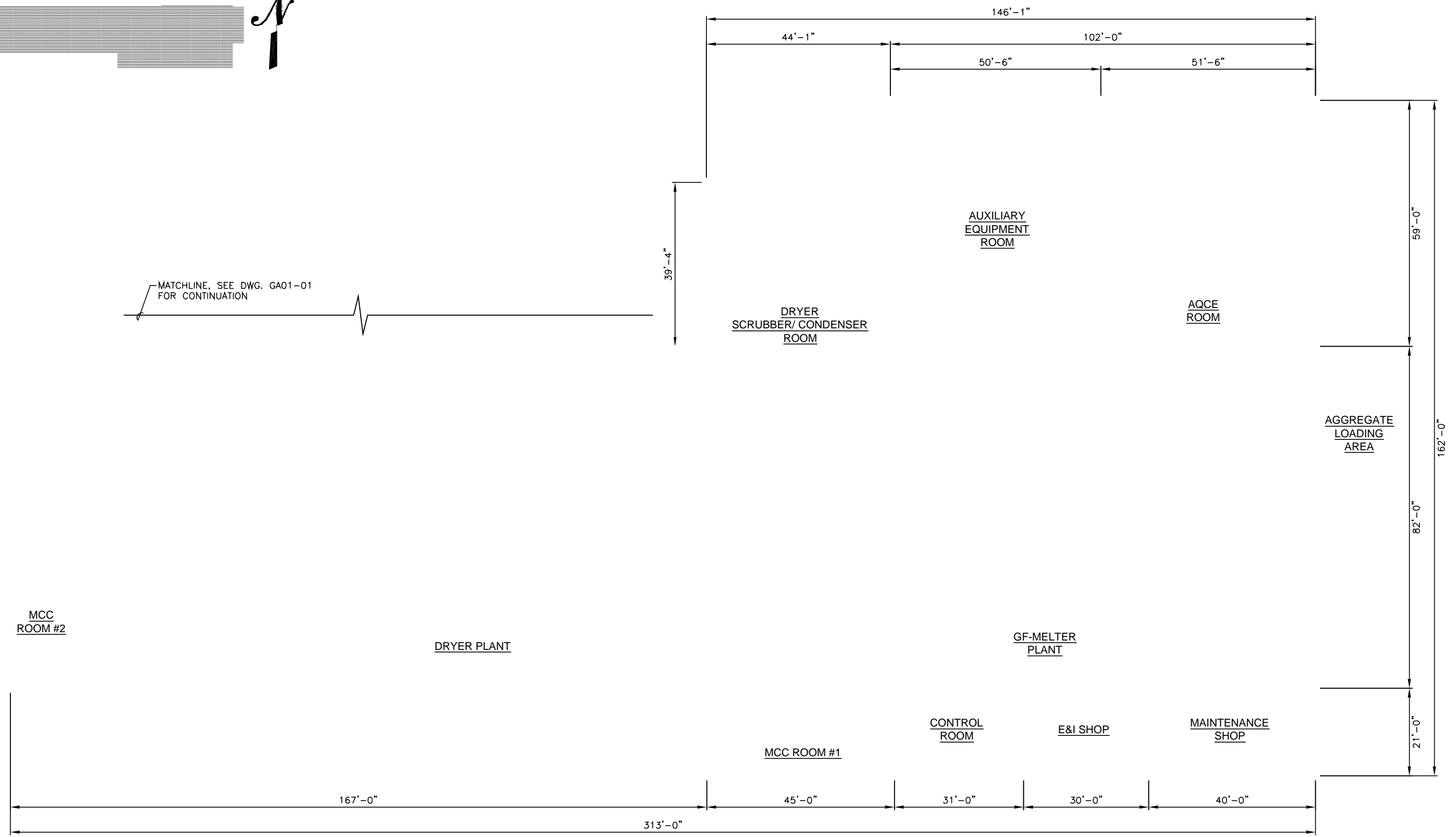

MCC ROOM #2

DRYER PLANT

DRYER SCRUBBER/CONDENSER ROOM

AUXILIARY EQUIPMENT ROOM

AQCE ROOM

AGGREGATE LOADING AREA

MCC ROOM #1

CONTROL ROOM

E&I SHOP

MAINTENANCE SHOP

GF-MELTER PLANT

PLAN VIEW AT GRADE EL.



THE DESIGN DATA AND INFORMATION CONTAINED HEREIN IS PROPRIETARY TO MINERGY / GLASSPACK LLC. NO PORTION OF THIS INFORMATION IS TO BE RELEASED EXCEPT AS AUTHORIZED THROUGH PRIOR WRITTEN APPROVAL BY MINERGY / GLASSPACK LLC.

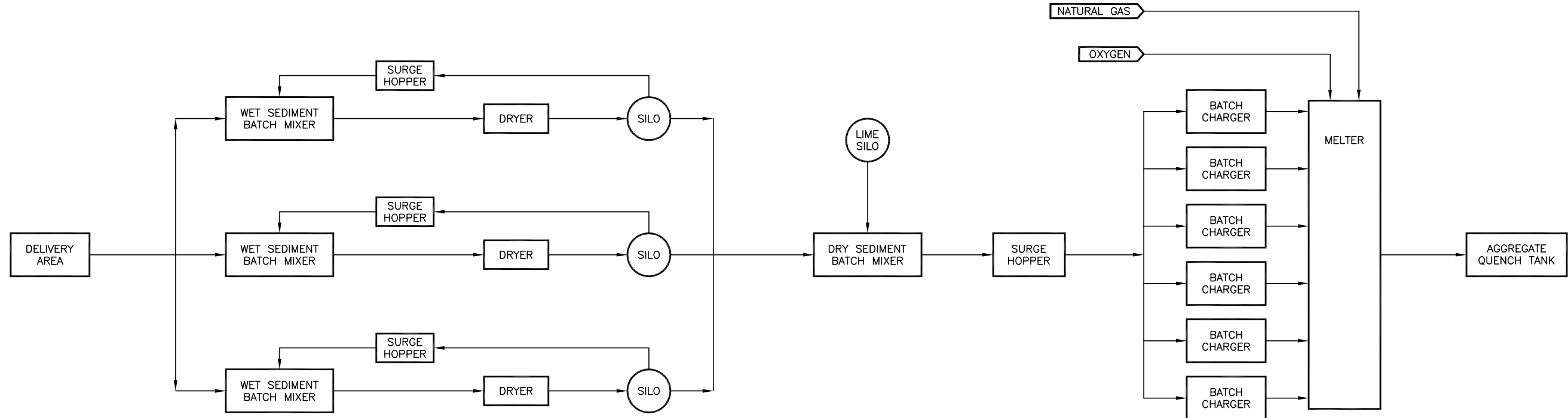

LEGEND:
 mc = MOISTURE CONTROL
 tpd = TONS PER DAY
 ts = TOTAL SOLIDS CONTENT

FOX RIVER SEDIMENT REMEDIATION
 250 GLASS TON PLANT
 NORTHEASTERN WISCONSIN

PROCESS FLOW DIAGRAM
 SEDIMENT DRYING & PREPARATION
 MAIN PROCESSING PLANT



CONFIDENTIAL
NOT FOR CONSTRUCTION

Date	11/28/01	RDK	TJB
Rev. No.	0	Issue for Review	
Rev. Description			
Drawn			Chkd

Date	FEBRUARY 2003
Drawing No.	250-1005-FD00
Sheet	01 OF 01
Rev.	0

THE DESIGN DATA AND INFORMATION CONTAINED HEREIN IS PROPRIETARY TO MINERGY / GLASSPACK LLC. NO PORTION OF THIS INFORMATION IS TO BE RELEASED EXCEPT AS AUTHORIZED THROUGH PRIOR WRITTEN APPROVAL BY MINERGY / GLASSPACK LLC.

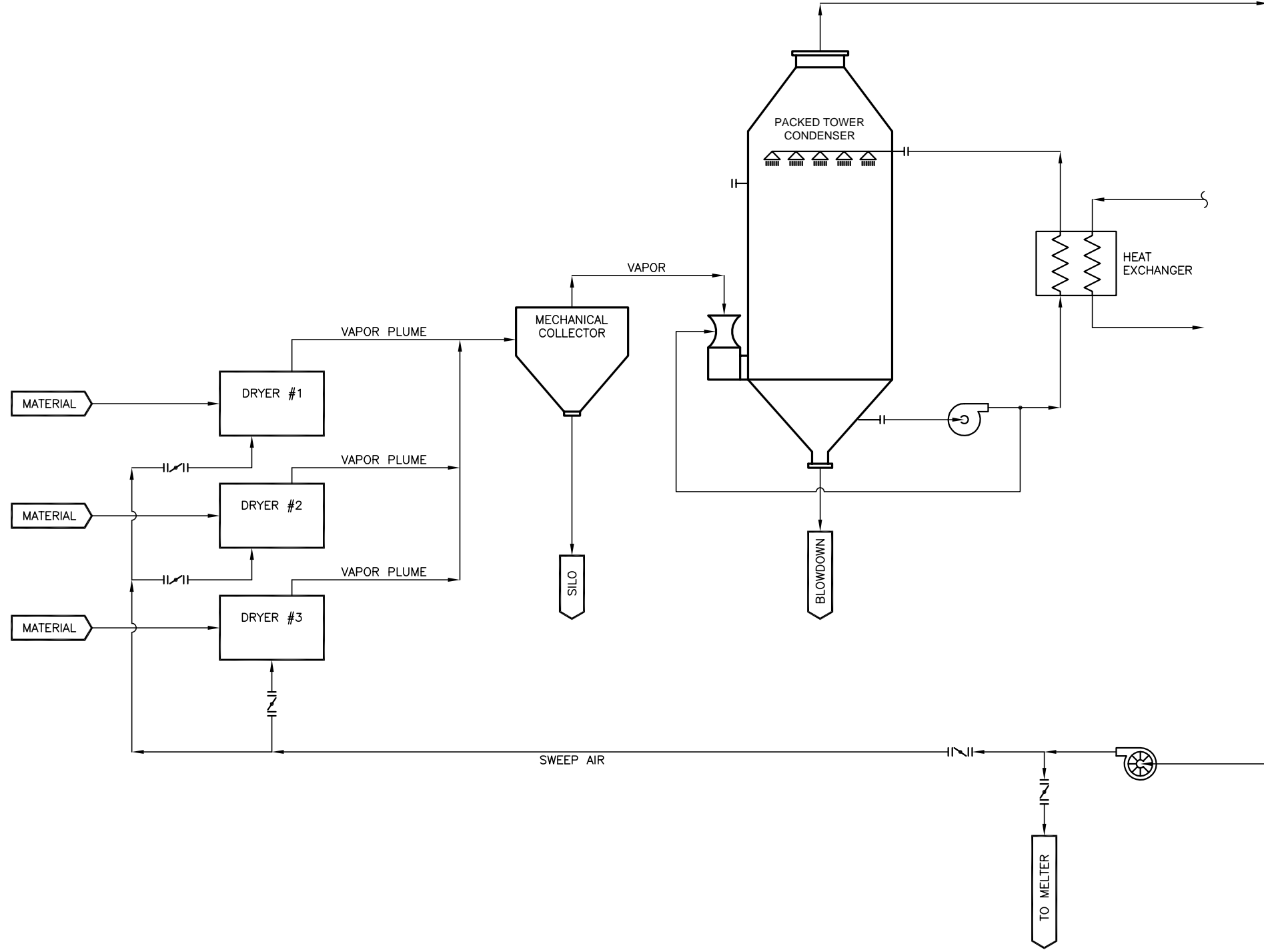

FOX RIVER SEDIMENT REMEDIATION
250 GLASS TON PLANT
NORTHEASTERN WISCONSIN

PROCESS FLOW DIAGRAM
DRYER OFF GAS TREATMENT
MAIN PROCESSING PLANT

Date
FEBRUARY 2003

Drawing No.
250-1005-FD01

Sheet 01 OF 01 Rev. 0

MINERGY
A WISCONSIN ENERGY CORPORATION
ENGINEERING

CONFIDENTIAL
NOT FOR CONSTRUCTION

Rev. No.	Description	Date	Drawn	Checked
0	ISSUE FOR REVIEW	11/28/01	RDK	TJB

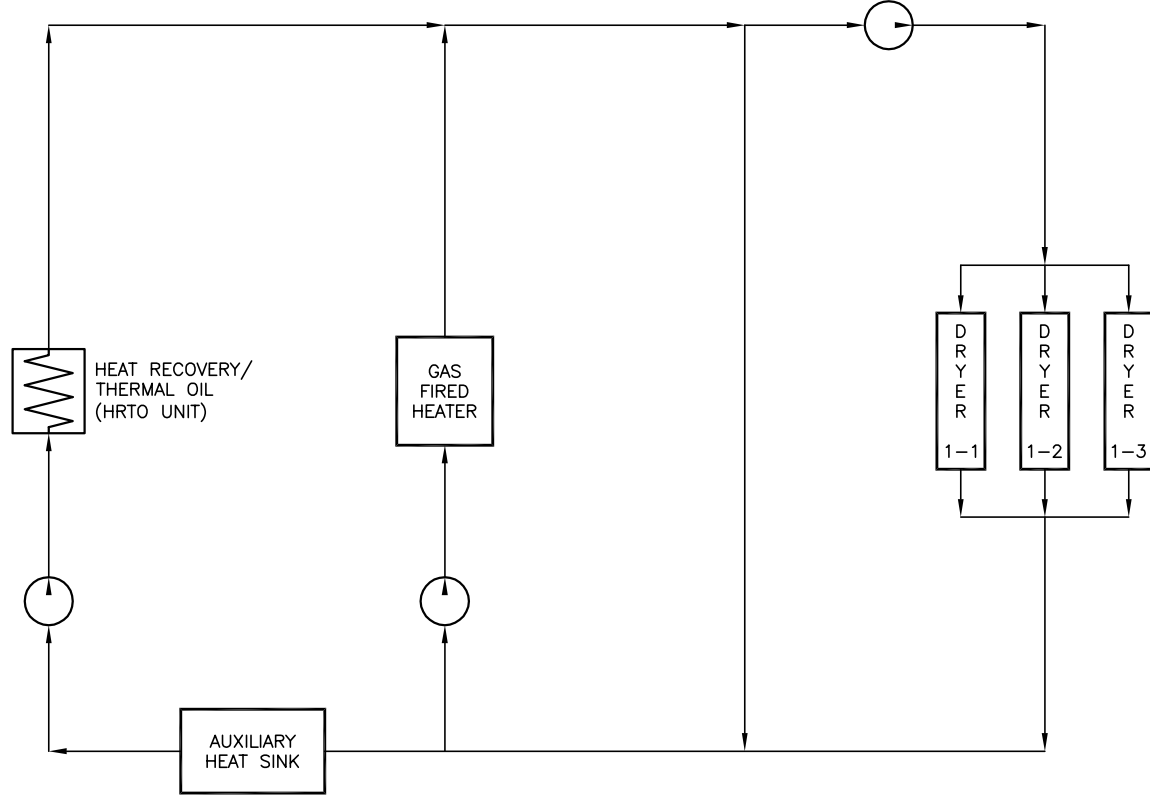

FOX RIVER SEDIMENT REMEDIATION
250 GLASS TON PLANT
NORTHEASTERN WISCONSIN

PROCESS FLOW DIAGRAM
THERMAL OIL SUPPLY SYSTEM
MAIN PROCESSING PLANT

Date
FEBRUARY 2003

Drawing No.
250-1005-FD02

Sheet 01 OF 01 Rev. 0



CONFIDENTIAL
NOT FOR CONSTRUCTION

0 ISSUE FOR REVIEW
Rev. No. Description

11/28/01 RDK TJB
Date Dwn. Chkd

THE DESIGN DATA AND INFORMATION CONTAINED HEREIN IS PROPRIETARY TO MINERGY / GLASSPACK LLC. NO PORTION OF THIS INFORMATION IS TO BE RELEASED EXCEPT AS AUTHORIZED THROUGH PRIOR WRITTEN APPROVAL BY MINERGY / GLASSPACK LLC.

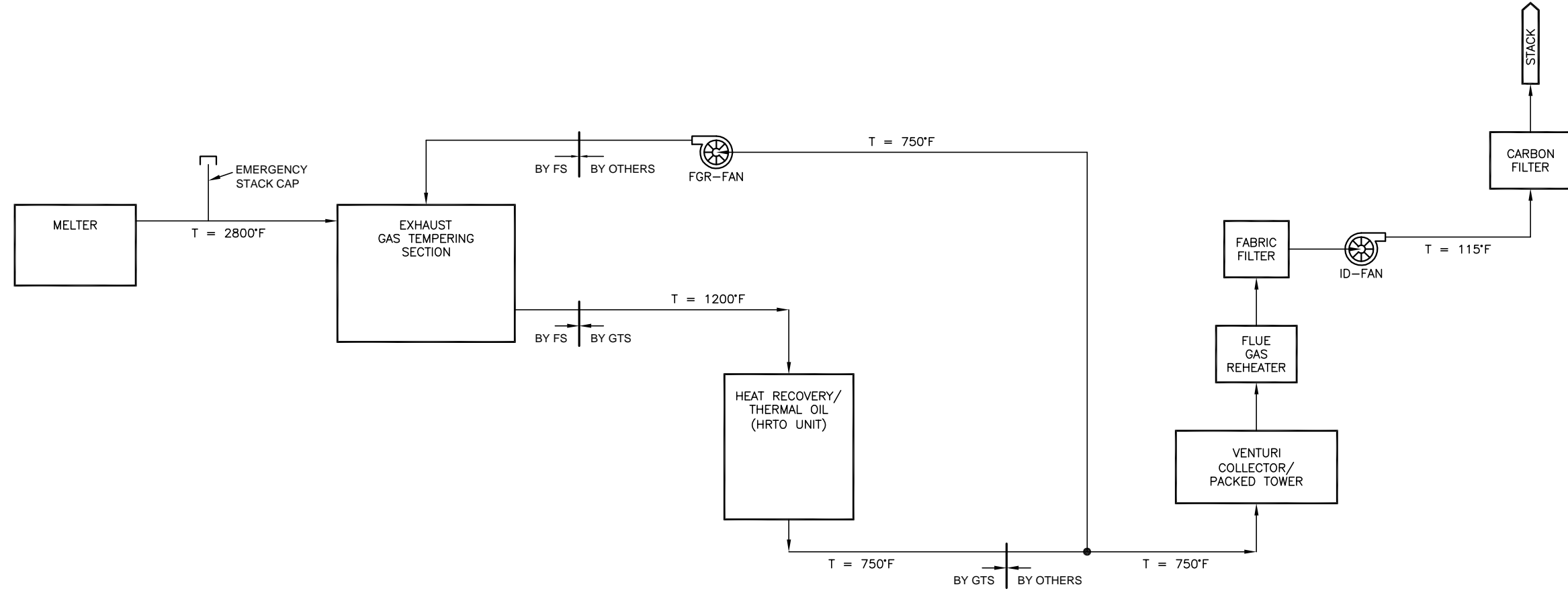

FOX RIVER SEDIMENT REMEDIATION
250 GLASS TON PLANT
NORTHEASTERN WISCONSIN

PROCESS FLOW DIAGRAM
MELTER EXHAUST HEAT RECOVERY & AQCE
MAIN PROCESSING PLANT

Date: FEBRUARY 2003
Drawing No.: 250-1005-FD03
Sheet: 01 OF 01 Rev: 0



CONFIDENTIAL
NOT FOR CONSTRUCTION

Rev. No.	Revision Description	Date	Drawn	Chkd
0	ISSUE FOR REVIEW	11/28/01	RDK	TJB