

| Presenter/ Time | Agenda Item | Key Points | Outcomes, Next Steps, Assignments |
|----------------------------|---|--|--|
| 9:03 | 1. Call to Order | <p>Members Present: Mike Cerny, Chair, Sam Landes, Donna White, Larry Erickson, Jon Schweitzer, Tom Chwala, Jerry Green, Rick Steimel, Mike Willman, Bob Lang, Tom Thornton, Karen Carlson, and Andy Malecki. Absent – Bev Dittmar, Vice Chair</p> <p>Others Present: Diane Conklin, Ed Slaminski, Gary Eddy – DNR, members of the media, public and AWSC</p> | |
| | 2. Acceptance of Minutes of Previous Meeting | | Motion by Donna White, second by Tom Thornton to approve minutes. <u>Motion carried.</u> |
| | 3. Comments | <p>Chair – Mike Cerny</p> <p>Attended the meeting Gary Eddy held with the various user groups to discuss the OWI-DL tie in.</p> | |
| | 4. Citizen Participation | <p><u>Public Comments</u></p> <p>Dave Peterson – Langlade Co Wolf River State Trail – opened this season. A nice addition to the system</p> <p>Craig Frey - Discussion regarding why there isn't any snowmobile safety for those over 25.</p> <p><u>AWSC</u> - Bill Schumann, President</p> <ul style="list-style-type: none"> • Didn't feel that the DNR was "coming to the plate" to assist. Specifically dealing with the types of penalties. • Wanted to thank the DNR wardens when they give interviews, they point out that the people that are harming wildlife are not part of the "Snowmobile Family". The biggest impact will come when clubs seek permission to use land for trails. • Last weekend there was an MS ride which provided \$250,000 to research. | |

| | | | |
|--|--|--|--|
| | | <ul style="list-style-type: none"> • AWSC is adopting a new slogan – SAS – Speed, Alcohol and Stupidity is the message when dealing with issues like wildlife damage. | |
| | 5. Reports | <p><u>State Trails Council - Tom Thornton</u></p> <ul style="list-style-type: none"> • Met in January, state parks contracts for grooming were requested. Tom requested that this be cleared by the April meeting. Parks indicated that they would have an update at that time. • Passed a resolution to support the non-motorized program and to utilize gas tax. <p><u>Department</u></p> <p><u>Law Enforcement - Gary Eddy</u></p> <ul style="list-style-type: none"> • Currently WI at 17, MN – 6, MI – 11 • Registrations – 224,000 - up since last year • Wildlife cases <ul style="list-style-type: none"> deer incident – charges continue to increase ducks – approximately \$2,500 in charges for the first incident. Second incident, still following up on leads. <p><u>Grants – Diane</u></p> <ul style="list-style-type: none"> • Time sheets – complete times in/out | |
| | 6. Reports of Standing Committees | <p><u>Tourism – Jerry Green</u></p> <ul style="list-style-type: none"> • Looking at placemats and maps • We’re setting up meetings with Dept of Tourism to discuss our program. <p><u>Finance Committee – Mike Cerny</u></p> <ul style="list-style-type: none"> • Updating supplemental overrun. We will pay back those final counties and state properties after July 1. Others will be paid as they come in until we run out of funds. <p><u>Infrastructure Committee – Andy Malecki</u></p> <ul style="list-style-type: none"> • Bridge Guidelines and Bridge inspections are in the works. It looks like the New Bridge Guidelines won’t go into effect until the changes are approved. The process for this to proceed is through the Natural | |

| | | | |
|--|--|--|--|
| | | <p>Resources Board to approve the concept and to hold public hearings, conduct public hearings and then take the results back to the board for approval before any changes can be made.</p> <ul style="list-style-type: none"> • Bridges on Federal property are becoming an issue. They do not feel our specs meet their criteria. We will be working with the USFS to resolve this. • Trail Arrows – we have standardized the arrow specs and will be producing new signing handbooks with the specs for this arrow included. • Again, regarding the arrows – it is very important that the STOP sign is the highest sign on a post. <u>Nothing</u> should stand higher, even it is attached to the back of the sign. There will be a clearer explanation in the signing handbook when it is reprinted. • Trail Issues – Sam Landes • Multi-use trails opening/closing policies needing to meet the criteria of the local counties. • Reclassification of DNR property. We have asked that we be included in this discussion when we have trails on the property. • Have snowmobiles included as one of the designated uses in 23.175(2)(a), Stats which currently states: <p>23.175(2)(a) “(a) Designate a system of state trails as part of the state park system for use by equestrians, bicyclists, riders of electric personal assistive mobility devices, cross-country skiers or hikers. The state trail system shall be named the "Aldo Leopold Legacy Trail System." “</p> <ul style="list-style-type: none"> • Grooming Equipment Report – still coming in. • Equipment Classification – rates that you start with are the rates you will end the year with. When DOT updates their rates, this will be taken care of at the beginning of the funding year. | |
|--|--|--|--|

| | | | |
|--|---|---|---|
| | | <ul style="list-style-type: none"> Looking at modifications to applications so we can gather more information before a funding meeting. <p><u>Law Enforcement – Rick Steimel</u></p> <ul style="list-style-type: none"> Some have expressed concern that penalties stemming from the snowmobile – wildlife killing incidents aren't strict enough. We have to respect the District Attorney's office with regard to any charges. Continue to conduct press releases to smooth things out as cases reach outcome. Fatal statistics: 17 fatalities in Wisconsin (15 last year). 13 Wisconsin residents, 2 MN, 2 Illinois. Recommendations: <ul style="list-style-type: none"> Tie in ALL recreation vehicles OWI's together Suspension of Recreational Vehicle Privileges Unify all OWI penalties to the highest current level Tie in second offense to the driver's license. Motion was made/passed by the committee, that if a person is arrested for OWI on a recreational vehicle, and is presently under a suspension or revocation for a motor vehicle OWI, then the recreational vehicle arrest would be considered a 2nd offense. Motion was made to reinstitute checkpoint stops. This motion did not pass the committee. | <p>Mike Cerny suggested that Finance Committee should look at the funding questions regarding this Accident Reduction Team and how we can possibly fund more of these.</p> <p>Motion by Jerry Green, second by Sam Landes to accept committee reports as stated. <u>Motion carried.</u></p> |
| | <p>7.Action Arising from Reports</p> | <p>No action items from Tourism or Finance.</p> <p>Infrastructure:</p> | <p>Motion to Contact Leon LaVigne, USFS regarding bridge specs. by Andy Malecki, second by Bob Lang. <u>Motion carried.</u></p> <p>Motion by Andy Malecki, second by Tom Thornton regarding the dimensions of the direction arrow as identified in the</p> |

| | | | |
|--|-------------------------|--|--|
| | | <p>Law Enforcement: The motions regarding OWI-DL tie-in will go back to the Multi-user Group who will take this information back to their respective groups. Upon each group's final decision and return to the multi-user group it will be and provide feedback and decide what the next steps should be.</p> | <p>attached diagram (Attachment 1). <u>Motion carried.</u></p> <p>Motion by Donna White, second by Larry Erickson to support the full amount of the non-resident trail pass, minus administrative cost (\$2.00) to go into the snowmobile supplemental account. <u>Motion carried.</u></p> <p>Motion by Rick Steimel, second by Mike Willman that if a person is arrested for an OWI on a recreational vehicle and is under suspension or revocation of DL for OWI, this arrest be considered as a second offense. <u>Motion carried.</u></p> <p>Motion by Rick Steimel, second by Bob Lang, to have the 3 page handout (Attachment 2) on penalties (provided by Gary) go before the full Council for further discussion. <u>Motion carried.</u></p> <p>Motion by Mike Willman to accept the changes identified in the handout, second by Tom Chwala. <u>Motion carried.</u></p> |
| | 8. Trail Matters | | |
| | 9. Member Items | Bob Lang – would like to have an Infrastructure meeting prior to the full council meeting for funding to review | |

| | | | |
|--|-------------------------|---|--|
| | | <p>project applications and request additional information.</p> <p><u>Groomer Show Observations:</u> Donna White – cost of operation may go up. Mike Cerny – more and more new equipment and “toys” or smaller equipment and how they fit into our current descriptions. Larry Erickson – Soucy track system seems to be a popular fill-in to convert tractor types. Jerry Green - rototiller on the back looks like a very handy accessory to put on the drag. Bob Lang – concerned about maintenance for things like rock jams, etc.</p> <p>Also, there will be a proposal coming forward regarding muzzle loader season from Dec 22 for 10 days until Dec 31.</p> <p>Tom Chwala/Diane Conklin - Hubbleton Bridge – Requesting a feeling for how an amendment for \$50,000 cost increase would be received as an amendment in April. The project will be completed by the end of June. No one spoke against the possibility of additional funds.</p> | |
| | 10. Next Meeting | | To be determined |
| | 11. Adjournment | | Motion to adjourn by Donna White, second by Tom Thornton. <u>Motion carried.</u> |

Attachment 1 – Arrow Diagram

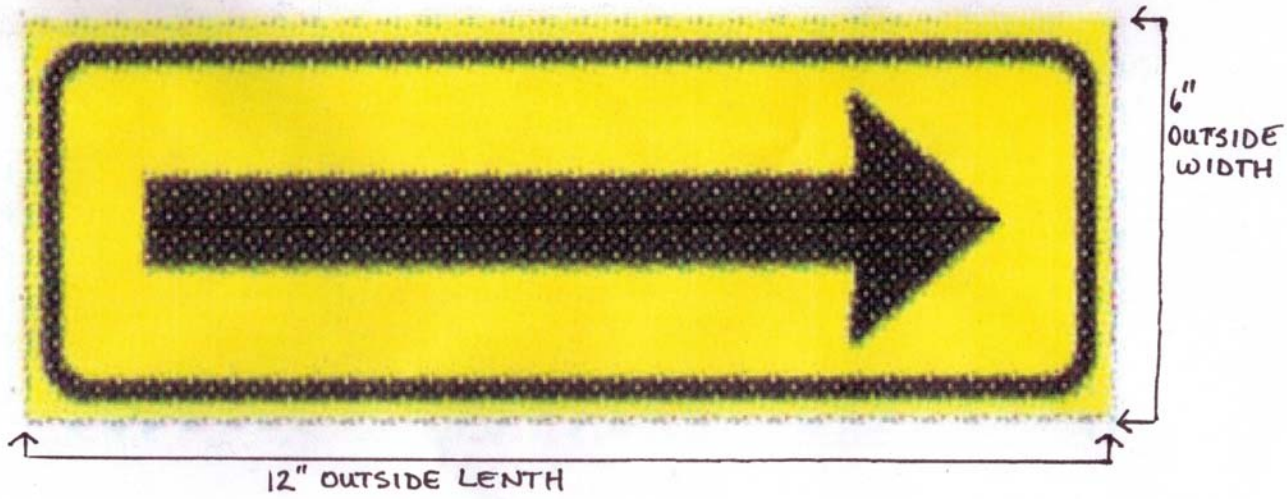
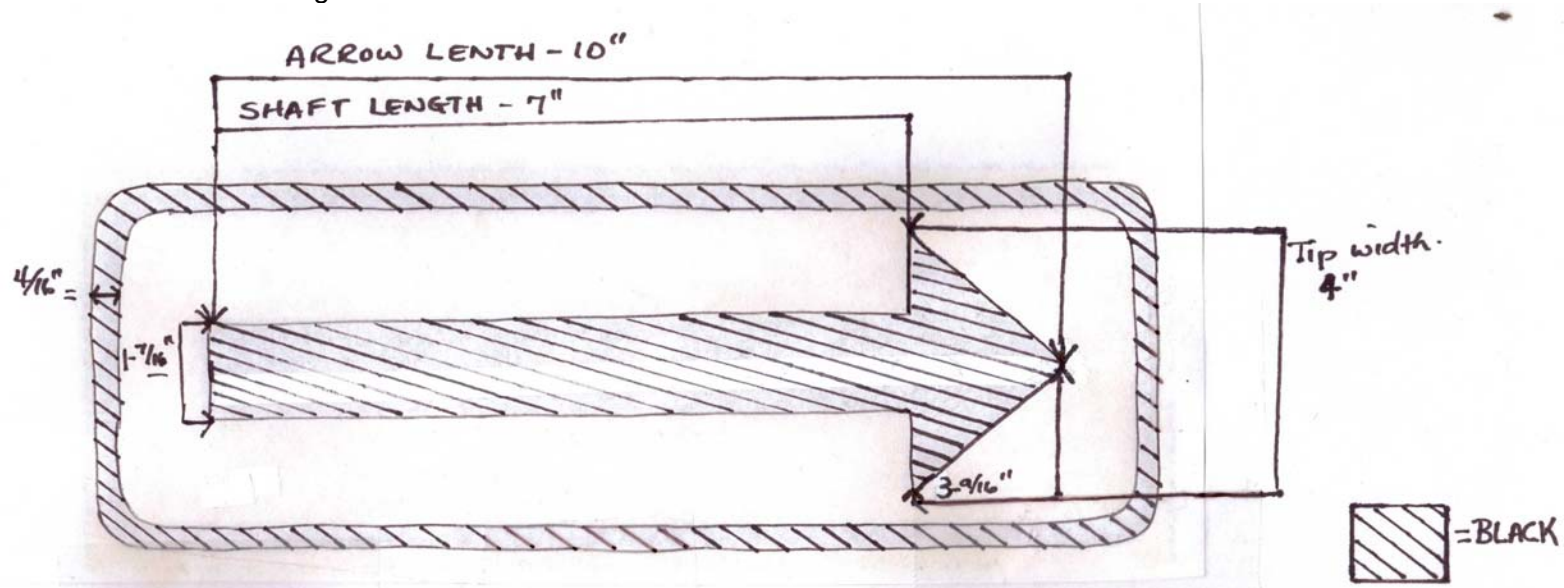

RECOMMENDATIONS

TIE-IN ALL REC. VEHICLE OWIs TOGETHER
SUSPENSION OF REC. VEHICLE PRIVILEGES
UNIFY ALL PENALTIES FOR OWI TO THE HIGHEST
CURRENT PENALTIES
TIE-IN SECOND OFFENSE TO THE DRIVER'S LICENSE

RECOMMENDATION # 1

TIE-IN ALL REC. VEHICLE OWIs
TOGETHER WITH A SUSPENSION
OF REC. VEHICLE OPERATING
PRIVILEGES

RECOMMENDATION # 2

UNIFY REC. VEHICLE OWI
PENALTIES SO THEY ARE ALL AT
HIGHEST CURRENT PENALTIES



Penalties



| | |
|---|--------------|
| OWI | = \$627.00 |
| OWI – w/passenger < 16 | = \$1,131.00 |
| 1 st Offense PAC (.08 – or more) | = \$627.00 |
| w/passenger <16 | = \$1,131.00 |
| Refusal | = \$627.00 |
| w/passenger <16 | = \$1,131.00 |

2nd and Additional Offenses



| | |
|--|---|
| 2 nd Offense OWI (within 5 yrs) | = CRIMINAL |
| | \$300 - \$1,100 Fine and 5 days - 6 mo.s |
| 3 rd Offense OWI (within 5 yrs) | = CRIMINAL |
| | \$600 - \$2,000 Fine and 1 mo.s – 1 year |
| 4 th Offense OWI (within 5 yrs) | = CRIMINAL |
| | \$1200 - \$4,000 Fine and 2 mo.s – 2 yrs. |
| 5 th Offense OWI (within 5 yrs) | = CRIMINAL |
| | \$1800 - \$6,000 Fine and 2 mo.s – 2 yrs. |
| Underage Passenger – everything doubles | |

Other Penalties



- Absolute Sobriety – under age 21
- Mandatory Alcohol Assessment
- Mandatory Safety Education Course

RECOMMENDATION # 3

TIE – IN 2nd OFFENSE WITH THE
DRIVER'S LICENSE



2nd O.D.

WISCONSIN IDENTIFICATION CARD
G555-5555-2555-00
REC'D A DRIVER LICENSE
SEX F HT 5-06 WT 140 HA BRN EYES BRN
DOB 08-28-1970 EXPIRES 08-28-2015
JANE QUINCY
SAMPLE WISCONSIN DRIVER
12345 6789
BLACK RIVER FALLS WI 54615-0000

If D.L. is currently suspended/revoked for motor vehicle OWI, then it's counted as a second offense on a rec. vehicle