



Mr. Eric Fuller and Ms. Kathleen McHugh
146 S. Marquette Street
Madison, Wisconsin 53704

Subject:
Results of Sub-Slab Depressurization System Inspection, 146 S. Marquette Street,
Madison, Wisconsin 53704

Dear Mr. Fuller and Ms. McHugh:

On December 10, 2013, ARCADIS personnel, on behalf of Madison-Kipp, completed an inspection of the sub-slab depressurization system (SSDS) at your home, located at 146 S. Marquette Street in Madison, Wisconsin.

Based on the observations made during the inspection, the SSDS is depressurizing the basement sub-slab appropriately. Attached please find the SSDS Maintenance Plan, which includes the SSDS Maintenance Log for these activities.

Should you have any questions regarding your SSDS, please contact Madison-Kipp:

Alina Walcek
Environmental and Safety Coordinator
Madison-Kipp Corporation
awalcek@madison-kipp.com
Office: 608-242-5200; Cell: 518-265-7183

Sincerely,

ARCADIS U.S., Inc.

Jennine L. Trask, PE
Project Manager

Copies:
Dr. Henry Nehls-Lowe – WDHS
Michael Schmoller – WDNR

Attachments:
1 – VenTech Dominator
2 – Inspection Form

ARCADIS U.S., Inc.
126 North Jefferson Street
Suite 400
Milwaukee
Wisconsin 53202
Tel 414 276 7742
Fax 414 276 7603
www.arcadis-us.com

ENVIRONMENT

Date:
February 13, 2014

Contact:
Jennine Trask

Phone:
414.277.6203

Email:
Jennine.trask@arcadis-us.com

Our ref:
WI001368.00005

Imagine the result

System Description

A combination sub-slab/sub-membrane depressurization system (SSDS) was installed at the home located at 146 South Marquette Street, Madison, Wisconsin as shown on Figure 1. The home is a two story with a combination foundation made up of a basement and three crawlspaces. The SSDS was installed to prevent vapor intrusion of tetrachloroethene (PCE).

System Design

The SSDS consists of one suction point located within the basement of the home and one suction point within each of the three crawlspaces. Crawlspace suction points consist of perforated piping installed beneath 6-mil polyethylene sheeting that was sealed to the perimeter of the crawlspace. All four suction points are plumbed to a VenTech Dominator 801 in-line fan located outside the north side of the home. System piping consists of 3-inch Schedule (Scd.) 40 polyvinyl chloride (PVC) installed from the crawlspaces which connected to 4-inch PVC piping extending from the basement suction point to the exterior fan and discharge. A short section of 2-inch Scd. 40 PVC piping was extended from the eastern crawlspace suction point before transitioning to 3-inch due to accessibility. The discharge is located approximately one foot above the roof line on the north side of the home. A u-tube manometer was installed on the system as shown on Figure 1. The fan is powered through a junction box and outlet. All electrical components are labeled. Photos of the SSDS components are attached.

System Maintenance

The VenTech Dominator 801 fan does not require routine maintenance. See attached manufacturer's specification sheet in Attachment 1.

The integrity of the crawlspace liners, basement floor and walls, and the presence of any modifications to the home or SSDS will be assessed during the annual inspections. The occupant of the home may also report any modifications or needed repairs at any time. Repairs will be made promptly to maintain the integrity of the liners and SSDS, as necessary. All repairs will be tracked on the inspection form presented in Attachment 2.

Inspections

Inspections will be completed annually and will be documented on the form presented in Attachment 2. A visual inspection of the system components will be completed. Any damaged system components will be repaired promptly. The manometer reading will be recorded and compared to the previous operating level. Sub-slab vacuum readings will be collected at test points and compared to previous readings. Any changes in the manometer or sub-slab vacuum operating levels will be evaluated and any necessary repairs or system modifications will be made promptly.

A copy of this Maintenance Plan and inspection forms will be kept on-site for reference by the homeowner.

Contacts

The homeowner may contact Madison-Kipp Corporation to coordinate any necessary system maintenance.

Alina Walcek
Environmental and Safety Coordinator
Madison-Kipp Corporation
awalcek@madison-kipp.com
Office: 608-242-5200
Cell: 518-265-7183

CITY:(Reqd) DIV:(GROUP):(Reqd) DB:(Reqd) LD:(Opt) PIC:(Opt) PM:(Reqd) TM:(Opt) LY:(Opt) OFF:REF-
 G:\Aproject\Madison\kipp\W001283\add\Residential VMS\146 S. Marquette Basement Layout\1113.DWG LAYOUT: 1 SAVED: 11/19/2013 3:42 PM ACADVER: 15.2S (LMS TECH) PAGES: 11/20/2013 12:17 PM BY: O'BRIEN, MAUREEN
 XREFS: IMAGES: PROJECTNAME: ---

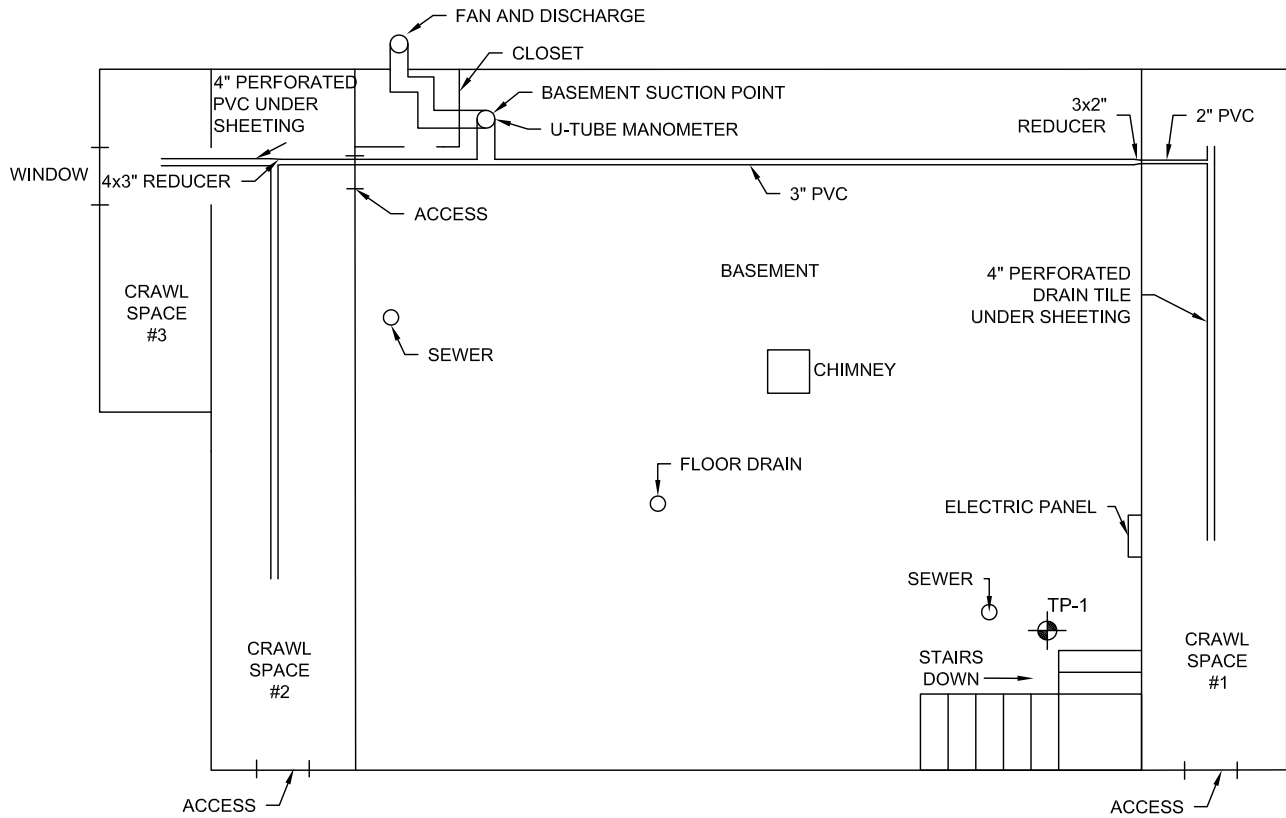

SPECIFICATIONS:

1. SSD SYSTEM PIPING: 4" THIN WALLED PVC, 2" AND 3" SCHEDULE 40 PVC
2. FAN: VENTECH DOMINATOR 801
3. TP-1: -0.026 IN.W.C. (MAY 30, 2012)
4. U-TUBE: 1.25 IN.W.C. (MAY 30, 2012)
5. OPENINGS: CRAWL SPACES SEALED WITH 6 MIL POLYETHYLENE SHEETING
6. DISCHARGE LOCATION: MEETS REQUIREMENTS, 1' ABOVE ROOFLINE
7. ELECTRICAL: JUNCTION BOX AND PLUG LABELED
8. FOUNDATION: UNFINISHED BASEMENT WITH CONCRETE FLOOR AND POURED WALLS, 3 CRAWL SPACES

LEGEND

-  TP-1 TEST POINT
- PVC POLYVINYL CHLORIDE
- IN.W.C. INCHES WATER COLUMN



NOT TO SCALE

MADISON KIPP CORPORATION 201 WAUBESA STREET MADISON, WISCONSIN	
SSD SYSTEM 146 S. MARQUETTE STREET	
	FIGURE 1



SSDS fan and discharge piping



Basement Suction Piping



Damper in Piping to Crawlspace



Manometer, operating level 1.50 in wc



West Crawlspace



East Crawlspace



Labeled plug controlling SSDS fan

VenTech Engineering

Model: "Dominator 801"

110V/60HZ

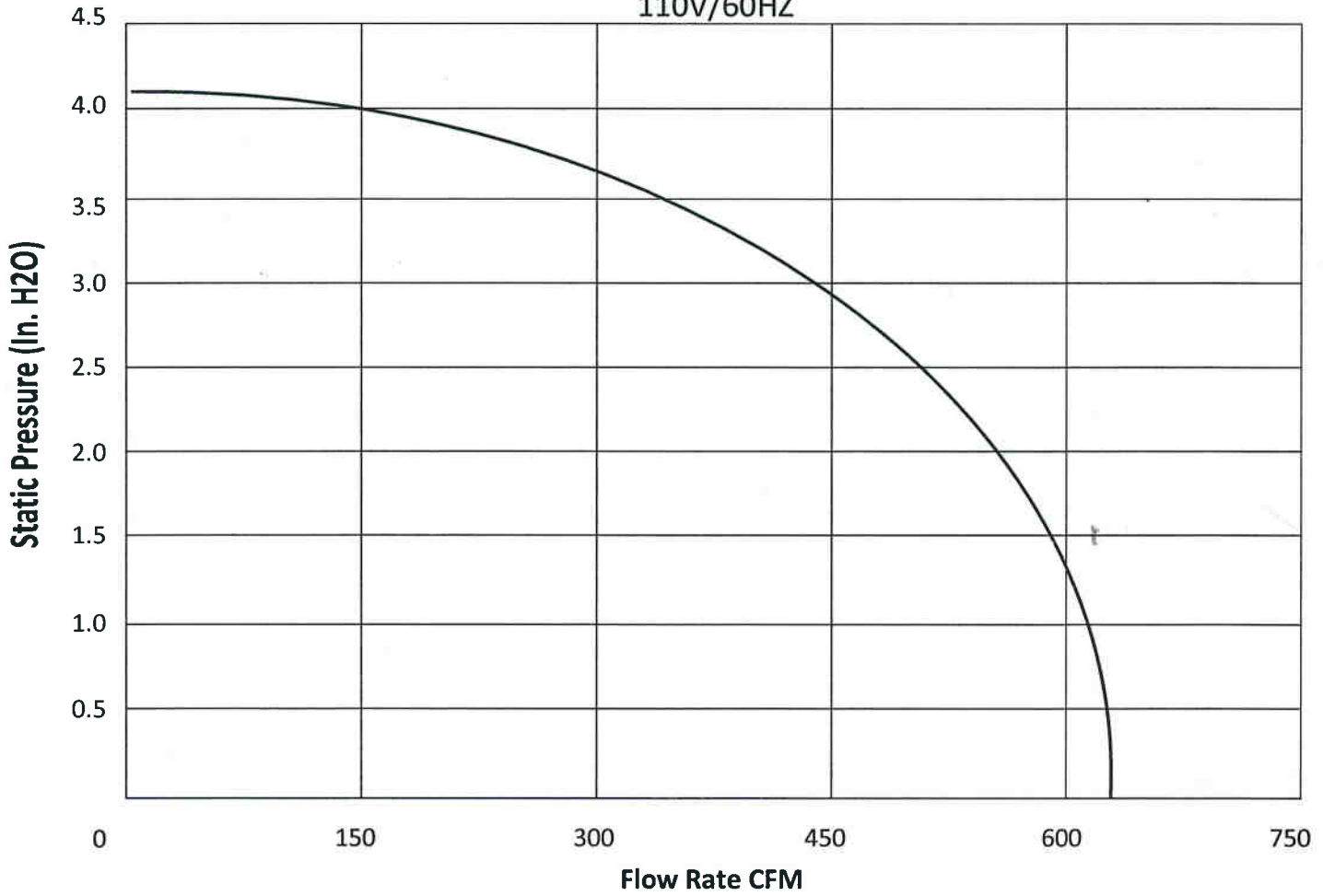

POWER (WATTS)	SPEED (RPM)	MAX AIR FLOW(CFM)	MAX PRESSURE (In. H2O)
60 - 150	2500	630	4.15

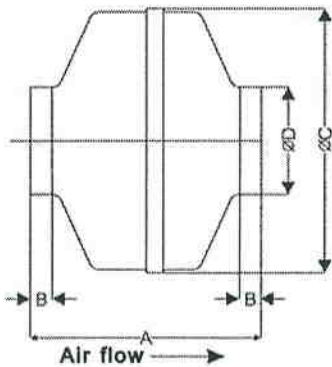

DIMENSIONS			
A	B	C	D
8.8"	1.0"	13.1"	4.5"

SSDS Maintenance Log, 146 South Marquette Street, Madison, Wisconsin

Date	Personnel	Company	U-tube (in wc)	TP-1 (in wc)	Fan operating properly?	Piping damaged?	Foundation and crawlspaces sealed?	List repairs needed	Initial repairs made	Notes
5/30/2012	R. Robbennolt	ARCADIS	1.25	-0.026	Yes	No	Yes	None	NA	
12/10/2013	R. Robbennolt, V. Yates, A. Walcek	ARCADIS, Madison-Kipp	1.5	-0.025	Yes	No	Yes	None	NA	TP-1 Installed